

Joint Institute for Nuclear Research

**Relativistic Nuclear Physics  
and Quantum Chromodynamics**

*Book of Abstracts  
of the XXIII International Baldin Seminar  
on High Energy Physics Problems*

Dubna, Russia, September 19-24, 2016

**Baldin ISHEPP XXIII**

Dubna 2016

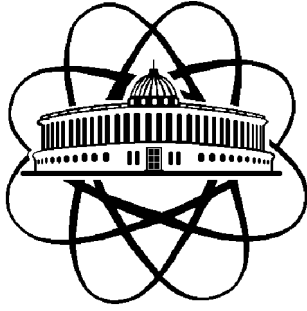

JOINT INSTITUTE FOR NUCLEAR RESEARCH  
**XXIII INTERNATIONAL BALDIN SEMINAR**  
**ON HIGH ENERGY PHYSICS PROBLEMS**

*RELATIVISTIC NUCLEAR PHYSICS*  
& *QUANTUM CHROMODYNAMICS*

dedicated to the 90th anniversary of Academician A.M. Baldin

**Dubna, Russia, September 19-24, 2016**

---

**International Advisory Committee**

A. Andrianov (Russia)  
A. Antonov (Bulgaria)  
Ts. Baatar (Mongolia)  
J. Carbonell (France)  
C. Ciofi degli Atti (Italy)  
J. Cleymans (South Africa)  
T. Donnelly (USA)  
S. Dubnička (Slovak Republic)  
M. Gazdzicki (Poland)  
P. Giubellino (CERN)  
H. Gutbrod (Germany)  
P. W.-Y. Hwang (Taiwan)  
V. Kekelidze (JINR)  
A. Kurepin (Russia)  
V. Kuvshinov (Belarus)  
H. Machner (Germany)  
L. Majling (Czech Republic)\*  
V. Matveev (JINR)  
Y. Musakhanov (Uzbekistan)  
Sh. Nagamiya (Japan)  
V. Novozhilov (Russia)  
Ch. Perdrisat (USA)  
W. Plessas (Austria)  
L. Pondrom (USA)  
G. Roepke (Germany)  
G. Salme (Italy)  
V. Savrin (Russia)  
L. Schroeder (USA)  
P. Senger (Germany)  
A. Shebeko (Ukraine)  
A. Slavnov (Russia)  
B. Slowinski (Poland)  
H. Stoecker (Germany)  
A. Thomas (USA)

\*deceased

H. Toki (Japan)  
E. Tomasi-Gustafsson (France)  
I. Tserruya (Israel)  
V. Voronov (JINR)  
Nu Xu (USA)  
G. Zinovjev (Ukraine)

**Organizing Committee**

V.V. Burov (Co-Chairman)  
A.I. Malakhov (Co-Chairman)  
S.G. Bondarenko (Vice-Chairman)  
E.P. Rogochaya (Scientific Secretary)  
E.N. Russakovich (Secretary)  
Yu.S. Anisimov  
A.A. Baldin  
I.V. Boguslavsky  
S.B. Gerasimov  
A.D. Kovalenko  
V.K. Lukyanov  
I.I. Migulina  
S.Z. Pakulyak  
Yu.A. Panebratsev  
N.M. Piskunov  
E.B. Plekhanov  
B.M. Starchenko  
O.V. Teryaev  
V.D. Toneev  
A.S. Vodopyanov  
P.I. Zarubin  
I.G. Zarubina

**E-mail:** <ishepp@theor.jinr.ru>

**Web-site:** <http://relnp.jinr.ru/ishepp/>

## **Organized by**

JOINT INSTITUTE FOR NUCLEAR RESEARCH

<http://www.jinr.ru/>

## **Supported by**

INTERNATIONAL UNION OF PURE AND APPLIED PHYSICS

<http://iupap.org/sponsored-conferences/approved-conferences/>

## **Sponsored by**

JOINT INSTITUTE FOR NUCLEAR RESEARCH

(Directorate Grant)

<http://www.jinr.ru/>

RUSSIAN FOUNDATION FOR BASIC RESEARCH

(Grant *N* 16-02-20311-*r*)

<http://www.rfbr.ru/>

## Contents

PHOTON PAIRS AND $\pi_0$ PAIRS PRODUCTION IN PROTON-NUCLEUS AND DEUTERON-NUCLEUS INTERACTIONS. RESULTS OF EXPERIMENTS ON INTERNAL BEAMS OF THE NUCLOTRON <i>Kh.U. Abraamyan et al.</i> .....	16
ON THE A-DEPENDENCE OF THE NEUTRON SINGLE-SPIN ASYMMETRY <i>V.V. Abramov</i> .....	17
POSSIBLE ORIGIN OF THE "RIDGE" EFFECT IN HEAVY-ION COLLISIONS <i>V.V. Abramov</i> .....	18
SUPPORTING THE EXISTENCE OF THE QCD CRITICAL POINT BY COMPACT STAR OBSERVATIONS <i>D. E. Álvarez-Castillo</i> .....	19
CHIRAL IMBALANCE IN QCD AND ITS CONSEQUENCES <i>A.A. Andrianov, V.A. Andrianov and D. Espriu</i> .....	20
STUDY OF $n_p$ - INTERACTIONS IN VBLHE JINR - HISTORY, CURRENT STATE, FUTURE <i>S. Arakelyan et al.</i> .....	21
ON RADIATIVE CORRECTIONS TO ELASTIC ELECTRON-PROTON SCATTERING <i>A.B. Arbuzov and T.V. Kopylova</i> .....	22
STUDY OF LIGHT NEUTRON DEFICIENT NUCLEI CLUSTER STRUCTURE WITH NUCLEAR TRACK EMULSIONS <i>D.A. Artemenkov</i> .....	24
ON SOME METHODOLOGICAL AND PHILOSOPHICAL IDEAS OF ACADEMICIAN A. M. BALDIN <i>A.A. Baldin</i> .....	25
OPTIMIZATION OF ACCELERATED CHARGED PARTICLE BEAM FOR ADS ENERGY PRODUCTION <i>A.A. Baldin et al.</i> .....	26
RELATIVISTICALLY INVARIANT SELF-SIMILARITY APPROACH FOR DESCRIPTION OF COLLECTIVE PHENOMENA <i>E.G. Baldina, A.A. Baldin</i> .....	27



A DATA SIMULATION MODEL OF THE BM@N GEM DETECTOR <i>D.A. Baranov, O.V. Rogachevsky</i> .....	28
A SUPERCONDUCTING CW-LINAC FOR HEAVY ION ACCELERATION AT GSI <i>W. Barth et al.</i> .....	29
KINEMATICAL FIT AND CHANNELS SEPARATION AT THE np-EXPERIMENTS AT JINR <i>A. Belyaev et al.</i> .....	30
RADIAL FLOW IN NON-EXTENSIVE THERMODYNAMICS AND STUDY OF PARTICLE SPECTRA AT LHC IN THE LIMIT OF SMALL $(q - 1)$ <i>Trambak Bhattacharyya et al.</i> .....	31
RECENT SELECTED THEORY DEVELOPMENTS FOR NICA <i>D.B. Blaschke</i> .....	33
RECENT RESULTS OF AZIMUTHAL ANISOTROPY MEASUREMENTS BY PHENIX <i>D.S. Blau for the PHENIX Collaboration</i> .....	34
DATA PROCESSING IN THE MODIFIED SETUP FODS <i>M.Yu. Bogolyubsky et al.</i> .....	35
GENERAL SPIN PARTICLE FORMALISM BASED ON SYMMETRY PROPERTIES AND MODEL-INDEPENDENT RESULTS <i>M. P. Chavleishvili</i> .....	36
MEASUREMENTS AND USAGE OF CROSS-SECTIONS OF VARIOUS (N,XN) THRESHOLD REACTIONS <i>P. Chudoba et al.</i> .....	37
TTH PRODUCTION AT 13 TeV <i>P.M. Cirkovic</i> .....	38
THERMAL MODEL DESCRIPTION OF COLLISIONS OF SMALL NUCLEI <i>J. Cleymans et al.</i> .....	39
BARYON ELECTROMAGNETIC FORM FACTORS AT BESIII <i>Alaa Dbeyss on behalf of BESIII collaboration</i> .....	40
ANALYSIS OF FRACTAL EVENTS WITH BACKGROUND <i>T.G. Dedovich and M.V. Tokarev</i> .....	41

NUMERICAL MODELING AND ANALYSIS OF THE MAGNETIC FIELD GENERATED BY THE SOLENOID FOR THE SPIN PROGRAM AT NICA	
<i>I. Dobrin et al.</i> .....	42
A STUDY OF HEAVY EXOTIC BARYON RESONANCES	
<i>Yubing Dong and Qifang Lyu</i> .....	43
EXPERIMENTAL INVESTIGATION OF THE INTERACTIONS THE HIGH ENERGY PROTONS WITH AN EXTENDED PB TARGETS	
<i>V. M. D'yachenko, I. M. Shevtsov</i> .....	44
PROBING THE LOW AND HIGH DENSITY NUCLEAR MATTER BY HADRON SCATTERING	
<i>S.M. Eliseev, O.S. Kosmachev</i> .....	45
FRAGMENTATION OF $^{16}\text{O}$ PROJECTILE IN NUCLEAR EMULSION AT 60 GEV	
<i>M.S.El-Nagdy et al.</i> .....	47
RELATIVE YIELD OF SECONDARY PARTICLES AND NUCLEAR FRAGMENTS IN FORWARD DIRECTION IN 20 A GeV/c CARBON BEAM INTERACTIONS WITH NUCLEAR TARGETS	
<i>M.Yu. Bogolyubsky et al.</i> .....	48
LORENTZ FORMULAS IN PROJECTIVE TRANSFORMATIONS	
<i>N.G. Fadeev</i> .....	49
J/ $\psi$ PRODUCTION AT THE STAR EXPERIMENT	
<i>Pavla Federičová for the STAR collaboration</i> .....	50
HEAVY FLAVOR MEASUREMENTS AT THE STAR EXPERIMENT	
<i>P. Federic for the STAR collaboration</i> .....	51
DRIFT CHAMBERS IN BM@N EXPERIMENT	
<i>Ján Fedorišin</i> .....	52
INITIAL STAGES AND COLLECTIVE EFFECTS IN HADRON COLLISIONS AT THE LHC	
<i>G.A. Feofilov</i> .....	53
TOWARD CENTRALITY DETERMINATION AT NICA/MPD	
<i>A.S. Galoyan, V.V. Uzhinsky</i> .....	54

THE FERMI COUPLING, THE MASS SPECTRUM AND DECAY CONSTANTS OF MESONS WITHIN THE COVARIANT CONFINED QUARK MODEL	
<i>Gurjav Ganbold</i> .....	55
NUCLEAR PHOTO-ABSORPTION SUM RULES AND SEARCH FOR EXOTICS	
<i>S.B. Gerasimov</i> .....	56
VECTOR MESON POLARIZATION VS COLOR TRANSPARENCY	
<i>S.R. Gevorkyan</i> .....	57
AMPLITUDES RATIOS IN $\rho^0$ LEPTOPRODUCTIONS AND GPDS	
<i>S.V. Goloskokov</i> .....	59
NEW STATES OF HADRONIC MATTER FROM THE DATA ON EXCLUSIVE MESON PRODUCTION WITH CLAS/CLAS12	
<i>E. Golovach and CLAS collaboration</i> .....	60
THE STUDY OF $B - S$ ANOMALY DECAYS IN COVARIANT QUARK MODEL	
<i>A. Issadykov</i> .....	61
INVESTIGATION OF REACTIONS USING POLARIZED AND UNPOLARIZED DEUTERON BEAM AT NUCLOTRON: CURRENT STATE AND PERSPECTIVES	
<i>M. Janek et al.</i> .....	62
NEW RENORMALIZATION-GROUP REPRESENTATION OF THE PERTURBATIVE EXPRESSIONS FOR THE BJORKEN POLARIZED SUM RULE AND THE $e^+e^-$ ANNIHILATION ADLER FUNCTION THROUGH THE PT CONFORMAL SYMMETRY BREAKING TERMS: THE RESULTS AND POSSIBLE PHENOMENOLOGICAL OUTPUTS	
<i>A. Kataev</i> .....	64
DEVIATION PATTERN APPROACH FOR OPTIMIZING PERTURBATIVE TERMS OF QCD RENORMALIZATION GROUP INVARIANT OBSERVABLES	
<i>M. Khellat and A. Mirjalili</i> .....	65
HADRON RAPIDITY DISTRIBUTIONS WITHIN A HYBRID MODEL HYDHSD	
<i>A.S. Khvorostukhin and V.D. Toneev</i> .....	67
COMPARISON OF NEUTRON INDUCED FISSION AND CAPTURE IN $N_p$ -237 AND $Pu$ -239 IRRADIATED IN QUINTA ASSEMBLY WITH 660 MeV PROTON BEAM	
<i>S. Kilim et al.</i> .....	68
HADRONIC RESONANCE PRODUCTION WITH ALICE AT THE LHC	
<i>Sergey Kiselev for the ALICE collaboration</i> .....	69

MODIFICATION OF THE STRANGE MESON PROPERTIES IN NUCLEAR MATTER	
<i>Yu.T. Kiselev et al.</i> .....	70
RECENT PROGRESS IN THE EXPERIMENTAL STUDY OF LIGHT NUCLEI PRODUCTION IN Pb+Pb COLLISIONS FROM THE NA49 EXPERIMENT	
<i>V.I. Kolesnikov</i> .....	71
ON THE POSSIBILITY TO OBSERVE THE TRANSITION OF A BARYON PAIR STATE TO A SIX-QUARK CONFINEMENT STATE	
<i>V.I. Komarov</i> .....	72
PHYSICS ARCHITECTURE	
<i>N.P. Konopleva</i> .....	74
ON THE ROLE OF “GHOSTS” IN THE PHYSICAL INTERPRETATION OF THE UNIVERSE MATTER EVOLUTION	
<i>V.M. Koryukin and A.V. Koryukin</i> .....	75
SOME NOTES ABOUT THE PROBLEMS OF RELATIVISTIC NUCLEAR PHYSICS	
<i>S.M. Eliseev, O.S. Kosmachev</i> .....	77
ON POSSIBLE CONTRIBUTION OF PARTONS’ ORBITAL MOMENTUM TO THE PROTON SPIN	
<i>B.F. Kostenko</i> .....	78
$\pi_0$ PRODUCTION IN dC- AND dCu-INTERACTIONS AT A MOMENTUM OF 4.5 GeV/c PER NUCLEON	
<i>Kh.U. Abraamyan et al.</i> .....	79
INVESTIGATION OF PROPERTIES OF $^{238}\text{U}$ , $^{237}\text{Np}$ , $^{239}\text{Pu}$ , AND $^{241}\text{Am}$ NUCLEI IN THE KVINTA NEUTRON FIELD AT JINR ACCELERATORS	
<i>S. Kilim et al.</i> .....	80
PROBING COMPOSITE MODELS AT THE LHC WITH EXOTIC QUARKS PRODUCTION	
<i>Romain Kukla</i> .....	82
DIGAMMA DIAGNOSTICS FOR THE MIXED-PHASE GENERATION AT NICA	
<i>V.I. Kukulin and M.N. Platonova</i> .....	84
NUCLEAR PARTON DISTRIBUTIONS	
<i>S.A. Kulagin</i> .....	86

TEST OF NUCLEAR FRAGMENTATION MODELS WITH CARBON FRAGMENTATION AT 0.3 GeV/n	
<i>B.M. Abramov et al.</i> .....	87
STUDY OF NUCLEAR FRAGMENTATION AT MPD/NICA	
<i>M.B. Golubeva, A.P. Ivashkin and A.B. Kurepin</i> .....	88
SUPERCONDUCTING DIPOLE MAGNET FOR THE CBM EXPERIMENT AT FAIR	
<i>P.K. Kurilkin et al.</i> .....	89
COLOUR EVOLUTION IN QCD VACUUM AT LARGE DISTANCES	
<i>V.I. Kuvshinov, E.G. Bagashov</i> .....	90
DELTA EXCITATION IN dp-ELASTIC SCATTERING AT THE INTERMEDIATE ENERGIES	
<i>N.B. Ladygina</i> .....	91
INVESTIGATIONS OF COMPRESSED BARYONIC MATTER AT THE GSI ACCELERATOR COMPLEX	
<i>V.P. Ladygin on behalf of JINR part of CBM collaboration</i> .....	92
QCD AND HADRONIC FINAL STATE MEASUREMENTS AT HERA	
<i>B.B. Levchenko on behalf of the H1 and ZEUS Collaborations</i> .....	93
SEARCH FOR THE SIGNS OF INTRINSIC ALPHA-CLUSTERING IN MULTIPARTICLE PROCESSES INDUCED BY COLLISIONS OF LIGHT NUCLEI	
<i>A.Kh. Arginova, A.Sh. Gaitinov, A.A. Loctionov</i> .....	94
THE COMPARATIVE ANALYSIS OF ELASTIC PION-NUCLEUS SCATTERING WITHIN THE MICROSCOPIC FOLDING AND LOCAL KISSLINGER-ERICSON OPTICAL POTENTIALS	
<i>V.K. Lukyanov et al.</i> .....	96
PDF OF HEAVY QUARKS AND GLUONS IN PROTON AND HARD PROCESSES AT LHC ENERGIES	
<i>G.I. Lykasov, A.V. Lipatov</i> .....	97
SPIN CORRELATIONS OF THE FINAL LEPTONS IN THE TWO-PHOTON PROCESSES $\gamma\gamma \rightarrow e^+e^-, \mu^+\mu^-, \tau^+\tau^-$	
<i>Valery V. Lyuboshitz in collaboration with</i> <span style="border: 1px solid black; padding: 2px;"><i>Vladimir L. Lyuboshitz</i></span> .....	98

RENORMDYNAMICS AND PRODUCTION OF FRACTALS, FLUCTONS, SOLITONS, STRINGS, UNPARTICLES ...	
<i>Nugzar Makhaldiani</i> .....	99
RATIOS OF HELICITY AMPLITUDES FOR EXCLUSIVE $\rho^0$ ELECTROPRODUCTION ON TRANSVERSELY POLARIZED PROTON	
<i>S.I. Manaenkov</i> .....	100
A NEW PLATFORM FOR RESEARCH AND APPLICATIONS WITH ELECTRONS AT ORSAY: PRAE	
<i>Dominique Marchand on behalf of the PRAE collaboration</i> .....	101
SEARCH FOR ANNUAL AND DAILY VARIATIONS OF Fe-55 NUCLEUS WEAK DE- CAY PARAMETERS	
<i>S.N. Mayburov</i> .....	102
INITIAL STATE FLUCTUATIONS IN HEAVY-ION COLLISIONS FROM SPS TO LHC	
<i>J. Milosevic</i> .....	103
HEAVY-HEAVY AND HEAVY-LIGHT QUARKS INTERACTIONS FROM INSTANTON VACUUM	
<i>M. Musakhanov</i> .....	104
THE ROLE OF INITIAL STATE IN HEAVY ION COLLISIONS. "HORN"-EFFECT	
<i>G. Musulmanbekov</i> .....	105
FEMTOSCOPIC MEASUREMENTS OF KAONS IN THE SELEX EXPERIMENT	
<i>G.A. Nigmatkulov</i> .....	106
EMISSION OF d, t, $^3\text{He}$ AND $\alpha$ -PARTICLES FROM $^{12}\text{C}$ NUCLEI EXCITED BY INTERMEDIATE ENERGY PHOTONS	
<i>A.A. Turinge, A.M. Lapik, A.N. Mushkarenkov, V.G. Nedorezov</i> <i>for the GRAAL collaboration</i> .....	107
ELECTROPRODUCTION OF LIGHTERST NUCLEON RESONANCES UP TO $Q^2=12 \text{ GeV}^2$ IN QUARK MODELS AT LIGHT FRONT	
<i>I.T. Obukhovskiy et al.</i> .....	108
PROBING THE X(3872) MESON STRUCTURE WITH NEAR-THRESHOLD pp AND pA COLLISIONS AT NICA	
<i>M.Yu. Barabanov et al.</i> .....	110
FIELD INDUCED PHASE TRANSITION IN THE FEW-PHOTON REGIME	
<i>A.D. Panferov et al.</i> .....	112

STUDY OF NEUTRON SPECTRA IN EXTENDED URANIUM TARGET. NEW EXPERIMENTAL DATA	
<i>M. Paraipan on behalf of the E&amp;T collaboration</i>	113
ULTRARELATIVISTIC TRANSVERSE MOMENTUM DISTRIBUTION OF THE EXACT TSALLIS STATISTICS	
<i>A.S. Parvan</i>	114
FOUNDATIONS OF A UNIFIED PHYSICS	
<i>Ivanhoe B.Pestov</i>	115
SIZE AND DISTANCE IN HIGH-ENERGY PHYSICS	
<i>V.A. Petrov</i>	117
MONTE CARLO MODELING OF NEUTRON GENERATION AND PROPAGATION IN URANIUM TARGET IRRADIATED WITH DEUTERON BEAM OF ENERGY FROM 1 GeV UP TO 8 GeV	
<i>Aleksander Polański</i>	118
ELECTROWEAK PROPERTIES OF $\rho$ -MESON IN THE INSTANT FORM OF RELATIVISTIC QUANTUM MECHANICS	
<i>A.F. Krutov, R.G. Polezhaev and V.E. Troitsky</i>	119
RECENT HEAVY ION RESULTS FROM THE ATLAS EXPERIMENT	
<i>M. Przybycien on behalf of ATLAS collaboration</i>	120
OVERVIEW OF ALICE RESULTS IN pp, pA AND AA COLLISIONS	
<i>R. Schicker on behalf of the ALICE collaboration</i>	121
ELASTIC EVENTS SELECTION IN INTERACTIONS OF THE COLLIDING $pp$ AND $dd$ BEAMS OF THE NICA COLLIDER	
<i>V.I. Sharov</i>	122
FORM FACTORS IN THE CLOTHED-PARTICLE REPRESENTATION	
<i>A.V. Shebeko</i>	124
FOUR ALL NN-SCATTERING AMPLITUDES	
<i>R.A. Shindin et al.</i>	125
PHENOMENOLOGICAL DESCRIPTION OF SPIN EFFECTS IN ELECTROMAGNETIC AND STRONG INTERACTIONS OF QUARKS	
<i>A.J. Silenko, O.V. Teryaev</i>	126

SCALING AND CORRELATIONS IN ELECTROMAGNETIC CASCADES PRODUCED BY GAMMA QUANTA IN DENSE AMORPHOUS MEDIA	
<i>B. Stowiński et al.</i> .....	127
QUASI-TWO-BODY PION-NUCLEUS COLLISIONS AT THE GeV ENERGY REGION AS AN INTRANUCLEAR SPACE PROBE	
<i>B. Stowiński et al.</i> .....	128
RESIDUAL CURRENTS GENERATED FROM VACUUM BY AN ELECTRIC FIELD PULSE IN 2+1 DIMENSIONAL QED MODELS	
<i>S.A. Smolyansky et al.</i> .....	129
STUDY OF $^{238}\text{U}(n, \gamma)$ AND $^{\text{nat}}\text{U}(n, f)$ REACTION RATES IN SPALLATION NEUTRON FIELDS PRODUCED BY PROTONS, DEUTERONS AND $^{12}\text{C}$ IONS ON THE MASSIVE URANIUM TARGET QUINTA	
<i>V. Sotnikov et al.</i> .....	130
AVERAGE FAST NEUTRON FLUX IN THREE ENERGY RANGES IN THE QUINTA ASSEMBLY IRRADIATED BY TWO TYPES OF BEAMS	
<i>E. Strugalska-Gola et al.</i> .....	132
MONTE CARLO SIMULATIONS OF YTTRIUM REACTION RATES IN QUINTA URANIUM TARGET	
<i>M. Suchopár et al.</i> .....	133
EFFECT OF THE $\eta\eta$ CHANNEL AND INTERFERENCE PHENOMENA IN THE TWO-PION TRANSITIONS OF CHARMONIA AND BOTTOMONIA	
<i>Yu.S. Suroutsev et al.</i> .....	134
LAMBDA POLARIZATION FEASIBILITY STUDY AT BM@N	
<i>D. Suvarieva, K. Gudima and A. Zinchenko</i> .....	136
COMPARISON OF TWO FAST NEUTRON MEASUREMENT METHODS BASED ON $\text{Np-237}$ FISSION TO CAPTURE RATIO MEASUREMENT (SPECTRAL INDEX) AND A REVERSE DARK CURRENT MEASUREMENT OF PLANAR SILICON DETECTOR	
<i>M. Szuta et al.</i> .....	137
STOCHASTIC NONLINEAR EQUATION OF QUARK-GLUON CASCADE	
<i>A.T. Temiraliev, I.A. Lebedev</i> .....	138
THE DIFFERENTIAL CROSS SECTION FOR dp-ELASTIC SCATTERING AT 500-900 MeV/n	
<i>A.A. Terekhin et al.</i> .....	140



HYPERONS POLARIZATION IN HEAVY-ION COLLISIONS	
<i>M. Baznat et al.</i> .....	141
IRRADIATION OF QUINTA ASSEMBLY BY 660 MeV PROTON BEAM AND 4 GeV AND 8 GeV DEUTERON BEAMS	
<i>P. Tichy et al.</i> .....	142
RECENT STAR HEAVY-ION RESULTS	
<i>M.V. Tokarev for the STAR Collaboration</i> .....	143
HIGHLIGHTS IN HADRON ELECTROMAGNETIC STRUCTURE	
<i>Egle Tomasi-Gustafsson, Andrea Bianconi and Simone Pacetti</i> .....	144
MINKOWSKI SPACE APPROACH FOR THE BETHE-SALPETER EQUATION	
<i>L. Tomio</i> .....	145
HEAVY ION COLLISIONS IN A FIXED TARGET MODE AT THE LHC BEAMS	
<i>A.B. Kurepin and N.S.Topilskaya</i> .....	146
CHARGE STRUCTURE OF $\Lambda$ -HYPERON	
<i>S.V. Trubnikov</i> .....	147
SEARCH FOR T-INVARIANCE VIOLATION IN $pD$ -SCATTERING	
<i>Yu.N. Uzikov</i> .....	148
LONG-RANGE RAPIDITY CORRELATIONS BETWEEN MEAN TRANSVERSE MOMENTA	
<i>V.V. Vechernin</i> .....	149
PROTON AND NEUTRON POLARIMETRY IN THE RANGE 1-6 GeV/c	
<i>Y. Wang et al.</i> .....	151
ESTIMATION OF TOLERANCES ON SYNCHROTRON ELEMENTS PARAMETERS FOR BIOMEDICAL RESEARCH	
<i>I.P. Yudin</i> .....	152
MANIFESTATION OF THE UNSTABLE NUCLEI IN RELATIVISTIC DISSOCIATION OF THE $^{10}\text{B}$ AND $^{11}\text{C}$ NUCLEI	
<i>A.A. Zaitsev</i> .....	153
DIFFRACTIVE DISSOCIATION OF RELATIVISTIC NUCLEI IN NUCLEAR TRACK EMULSION	
<i>P.I. Zarubin</i> .....	154

STUDY OF THE CHARACTERISTICS OF MONOLITHIC ACTIVE PIXEL DETECTORS FOR THE NEW ALICE INNER TRACKING SYSTEM	
<i>V.I. Zhrebchevsky et al.</i> .....	155
NLO ELECTROWEAK RADIATIVE CORRECTIONS FOR 4-FERMIONIC PROCESS AT BELLE II	
<i>A.G. Aleksejevs, S.G. Barkanova, and V.A. Zykunov</i> .....	156
RECENT DEVELOPMENTS IN MPD TRACKING AND DETECTOR PERFORMANCE IN HADRON IDENTIFICATION	
<i>A.I. Zinchenko, A.A. Mudrokh</i> .....	158

# PHOTON PAIRS AND $\pi^0$ PAIRS PRODUCTION IN PROTON-NUCLEUS AND DEUTERON-NUCLEUS INTERACTIONS. RESULTS OF EXPERIMENTS ON INTERNAL BEAMS OF THE NUCLOTRON

Kh.U. Abraamyan<sup>1,2</sup>, A.B. Anisimov<sup>1</sup>, M.I. Baznat<sup>3</sup>, K.K. Gudima<sup>3</sup>, M.A. Kozhin<sup>1</sup>,  
V.I. Kukulin<sup>4,5</sup>, M.A. Nazarenko<sup>6</sup>, S.G. Reznikov<sup>1</sup>, and A.S. Sorin<sup>1,7</sup>

1. *VBLHEP JINR, 141980 Dubna, Moscow region, Russia*
2. *Yerevan State University, 0025, Yerevan, Armenia*
3. *Institute of Applied Physics, MD-2028 Kishinev, Moldova*
4. *Institute of Nuclear Physics, Moscow State University, 119992, Moscow, Russia*
5. *Institut für Theoretische Physik, Universität Tübingen, Auf der Morgenstelle 14, D-72076 Tübingen, Germany*
6. *Moscow State Institute of Radioengineering, Electronics and Automation, 119454 Moscow, Russia*
7. *BLTP JINR, 141980 Dubna, Moscow region, Russia*

The results of experiments on photon pairs and  $\pi^0$  pairs production in interactions of 5.5 GeV/c protons, 2.75 and 3.83 GeV/c per nucleon deuterons with carbon and copper nuclei are presented. Along with  $\pi^0$  and  $\eta$  mesons, a resonance structure in the invariant mass spectrum of two photons at  $M_{\gamma\gamma} = 360 \pm 7 \pm 9$  MeV is observed in the reaction  $dC \rightarrow \gamma + \gamma + X$  at momentum 2.75 GeV/c per nucleon. Estimates of its width and production cross section are  $\Gamma = 64 \pm 18$  MeV and  $\sigma_{\gamma\gamma} = 98 \pm 24_{-67}^{+93}$   $\mu\text{b}$ , respectively. The collected statistics amount to  $2339 \pm 340$  events of  $1.5 \cdot 10^6$  triggered interactions of a total number  $\sim 10^{12}$  of  $d + C$  interactions. This resonance structure is not observed in the  $\gamma\gamma$  channel in  $\sim 10^{11}$   $p + C$  collisions at the beam momentum 5.5 GeV/c. The result obtained in the reaction  $d + C$  is confirmed by the second experiment carried out on the deuteron beam at momentum 3.83 GeV/c per nucleon with a copper target:  $M = 382 \pm 13$  MeV,  $\Gamma = 62 \pm 37$  MeV and  $\sigma = 273 \pm 75$   $\mu\text{b}$ . Some results on observation of the resonance in the invariant mass spectra of two  $\pi^0$  mesons are presented: the data obtained in the  $d + C \rightarrow \gamma + \gamma + X$  reaction is confirmed by the results for the  $d + C \rightarrow \pi^0 + \pi^0 + X$  and  $p + C \rightarrow \pi^0 + \pi^0 + X$  reactions; a preliminary estimate of the ratio  $Br(R \rightarrow \gamma\gamma) / Br(R \rightarrow \pi^0\pi^0)$  is:  $(1.8-3.7) \cdot 10^{-3}$ . The results of testing of the observed signal are presented. Further studies of this resonance is assumed at the Nuclotron/NICA at higher setup acceptance, which will allow to elucidate the nature of this resonance by determination of the differential cross sections at different beam energies in the range of 1–6 GeV/n and the mechanism of its formation. The conditions required for observation of this resonance are discussed.

# ON THE A-DEPENDENCE OF THE NEUTRON SINGLE-SPIN ASYMMETRY

V.V. Abramov

*National Research Centre "Kurchatov Institute" State Research Center of Russian Federation -  
INSTITUTE FOR HIGH ENERGY PHYSICS, Protvino, Russia  
E-mail: Victor.Abramov@ihep.ru*

Preliminary data of PHENIX experiment on single-spin asymmetry ( $A_N$ ) for a neutron production in a proton-nucleus collisions are discussed [1]. The measurements were carried out in p+p, p+Al and p+Au - collisions at an energy of 200 GeV in the cms. Completely unexpected  $A_N$  dependence on atomic weight (A) of the target nucleus is found. Asymmetry changes its sign and increases three-fold during the transition from p+p to p+Au-interactions. This unusual behavior is explained by the chromomagnetic polarization of quark (CPQ) model [2-5]. The anomalous A-dependence is due to Stern-Gerlach force and quark spin precession in effective color field. Detailed predictions of the single-spin asymmetry in the production of neutrons for various kinematic regions are given. Predictions of the CPQ model can be tested in experiments SPASCHARM(IHEP), SPD(JINR), STAR and PHENIX.

## References

- [1] Minjung Kim, PHENIX Forward Neutron Single Transverse Spin Asymmetry  $A_N$  Measurements, International Workshop on High Energy Scattering at Zero Degrees, Nagoya, Japan, September 09-12, 2015.
- [2] V.V. Abramov, Phys. At. Nucl. **72**, 1872 (2009).
- [3] V.V. Abramov, J. Phys. Conf. Ser. **295**, 012086 (2011).
- [4] V.V. Abramov, Phys. Part. Nucl. **45**, 62 (2014).
- [5] V.V. Abramov, J. Phys. Conf. Ser. **678**, 012039 (2016).

# POSSIBLE ORIGIN OF THE "RIDGE" EFFECT IN HEAVY-ION COLLISIONS

V.V. Abramov

*National Research Centre "Kurchatov Institute" State Research Center of Russian Federation -  
INSTITUTE FOR HIGH ENERGY PHYSICS, Protvino, Russia  
E-mail: Victor.Abramov@ihep.ru*

Experiments at the RHIC (PHENIX, PHOBOS, STAR) and the LHC (ATLAS, CMS, ALICE, LHCb) colliders have shown that in the two-particle correlations there are two narrow peaks for the difference of azimuthal angles (about 0 and 180 degrees), as well as two peaks in the difference of pseudorapidities which become wider with increasing centrality of collisions [1, 2, 3]. The observed long-range correlations in the near side (at low relative azimuth angles and large relative pseudorapidities) is called the "ridge". This is very unusual behavior, which does not yet have a convincing explanation. The natural explanation of the "ridge" effect offered in the framework of the chromomagnetic polarization of quark model (CPQ) [4-7]. The observed effect is due to the Lorentz force, which acts on the color charge of the quark in the effective circular transverse chromomagnetic field as is supposed in the CPQ model. Since the intensity of the effective color field increases with the colliding ion masses, collisions centrality, and a multiplicity of particles in an event that leads to widening of the peak versus relative pseudorapidity, whereas peak in relative azimuth angle is not changed significantly by the action of the Lorentz force. CPQ model reproduces the dependence of the width of the peaks on the mass of the colliding nuclei, the transverse momentum of the hadrons, as well as the centrality of the collision. Predictions are obtained for different energy, collisions centrality and the masses of the colliding ions.

## References

- [1] David Kettler for the STAR collaboration, J. Phys. Conf. Ser. **270**, 012058 (2011).
- [2] D.T. Kettler, D.J.Prindle, T.A.Trainor, Phys. Rev. **C 91**, 064910 (2015).
- [3] B. Abelev et al., Phys. Lett. **B 719**, 29 (2013).
- [4] V.V. Abramov, Phys. At. Nucl. **72**, 1872 (2009).
- [5] V.V. Abramov, J. Phys. Conf. Ser. **295**, 012086 (2011).
- [6] V.V. Abramov, Phys. Part. Nucl. **45**, 62 (2014).
- [7] V.V. Abramov, J. Phys. Conf. Ser. **678**, 012039 (2016).

# SUPPORTING THE EXISTENCE OF THE QCD CRITICAL POINT BY COMPACT STAR OBSERVATIONS

D. E. Álvarez-Castillo

*Bogoliubov Laboratory for Theoretical Physics,  
Joint Institute for Nuclear Research,  
Dubna, Russian Federation*

In order to prove the existence of a critical end point (CEP) in the QCD phase diagram it is sufficient to demonstrate that at zero temperature  $T = 0$  a first order phase transition exists as a function of the baryochemical potential  $\mu$ , since it is established knowledge from ab-initio lattice QCD simulations that at  $\mu = 0$  the transition on the temperature axis is a crossover.

We present the argument that the observation of a gap in the mass-radius relationship for compact stars which proves the existence of a so-called third family (aka "mass twins") will imply that the  $T = 0$  equation of state of compact star matter exhibits a strong first order transition with a latent heat that satisfies  $\Delta\epsilon/\epsilon_c > 0.6$ . Since such a strong first order transition under compact star conditions will remain first order when going to symmetric matter, the observation of a disconnected branch (third family) of compact stars in the mass-radius diagram proves the existence of a CEP in QCD. Modeling of such compact star twins is based on a QCD motivated NJL quark model with high order interactions together with the hadronic DD2-MEV model fulfilling nuclear observables.

Furthermore we show results of a Bayesian analysis (BA) using disjunct M-R constraints for extracting probability measures for cold, dense matter equations of state. In particular this study reveals that measuring radii of the neutron star twins has the potential to support the existence of a first order phase transition for compact star matter.

# CHIRAL IMBALANCE IN QCD AND ITS CONSEQUENCES

A.A. Andrianov<sup>1,2†</sup>, V.A. Andrianov<sup>1</sup> and D. Espriu<sup>2</sup>

(1) *Faculty of Physics, Saint Petersburg State University, Universitetskaya nab. 7/9, Saint Petersburg 199034, Russia*

(2) *Departament de Física Quàntica i Astrofísica and Institut de Ciències del Cosmos (ICCUB), Universitat de Barcelona, Martí i Franquès 1, 08028 Barcelona, Spain*

† *E-mail: a.andrianov@spbu.ru*

Under extreme conditions of high temperature and/or large quark (baryon) density, the vacuum of QCD changes its properties, and deconfinement, chiral symmetry restoration as well as chiral symmetry breaking take place. These transitions (phases) are accompanied by the rapid change in the rate and nature of topological transitions connecting different topological sectors. The heavy ion collisions (HIC) program opens a possibility to study these phenomena in so-called non-Abelian Quark-gluon plasma (QGP) as well as their manifestation in the hadron phase. In these phases the currents of light quarks (vector and axial-vector) can be independently examined for right-handed (RH) and left-handed (LH) quarks. To describe such a quark matter chiral chemical potential can be introduced to quantify the presence of chirality imbalance (ChI) i.e. the difference between the average numbers of RH and LH quarks in the fireball after HIC. In this review talk we will focus our attention on the discussion of the ChI related developments in heavy ion physics at central collisions and the plans for the future experiments aimed at establishing (or falsifying) the presence of Local Parity Breaking (LPB) in heavy ion data. We indicate some of experimental observables in detecting the signal of LPB. Based on the effective meson theory in the presence of Chern-Simons interaction it is found that the spectrum of massive vector mesons splits into three polarization components with different effective masses [1]. Moreover a resonance broadening occurs that leads to an increase of spectral contribution to the dilepton production as compared to the vacuum state. The asymmetry in production of longitudinally and transversely polarized states of  $\rho$  mesons for various values of the dilepton invariant mass can serve as a characteristic signature of the LPB in collider experiments [2]. **We describe:**

Where and how does chiral imbalance appear: Phenomenology of parity breaking in finite volume.

Chiral imbalance in quark-gluon phase: topological charge vs. axial (chiral) charge: topological vs. chiral chemical potentials.

Chiral imbalance in hadronic phase: scalar, pseudoscalar, vector meson spectra.

Observables sensitive to chiral imbalance - manifestation of LPB in heavy ion collisions (HIC): dilepton polarization asymmetry .

## References

- [1] A. A. Andrianov, D. Espriu and X. Planells, Eur. Phys. J. C **73**, no. 1, 2294 (2013); Eur. Phys. J. C **74**, no. 2, 2776 (2014)
- [2] A. A. Andrianov, V. A. Andrianov, D. Espriu and X. Planells, Phys. Lett. B **710**, 230 (2012); Phys. Rev. D **90**, no. 3, 034024 (2014)

## **STUDY OF $np$ - INTERACTIONS IN VBLHE JINR - HISTORY, CURRENT STATE, FUTURE**

S. Arakelyan, A. Belyaev, A. Jerusalimov, V. Pechenov, A. Troyan

The review and analysis of works about interaction of quazimonochromatic neutron beams with proton 1-m hydrogen bubble chamber VBLHE JINR are presented. Possibilities of using results of these studies in modern experiments are shown. The prospects of the further processing the experimental material are presented.



# ON RADIATIVE CORRECTIONS TO ELASTIC ELECTRON-PROTON SCATTERING

A.B. Arbuzov<sup>1,2†</sup> and T.V. Kopylova<sup>2</sup>

(1) *Bogoliubov Laboratory of Theoretical Physics, JINR, Dubna, 141980 Russia*

(2) *Department of Higher Mathematics, Dubna State University, Dubna, 141982 Russia*

† *E-mail: arbuzov@theor.jinr.ru*

Higher order QED radiative corrections to elastic electron-proton scattering at low energies were considered in [1]. Corrections to the electron line and effects due to vacuum polarization were computed. Higher order effects are estimated for the conditions of the experiment on the electric and magnetic proton form factors by A1 Collaboration at the Mainz Microtron (MAMI) [2]. The transferred momentum range  $0.003 < Q^2 < 1 \text{ GeV}^2$  was exploited at the experiment. Numerical computations are performed for the MAMI experimental set-up. The average point-to-point errors in the cross sections measurement was of the order of a few permille. That gives the requirement on the theoretical precision to be at least one permille. For this reason, the analytical calculations should be performed within the next-to-leading logarithmic approximation [3, 4]. The differential cross section  $d\sigma/d\Omega_e$  of the process

$$e(p_1) + p(P_1) \longrightarrow e(p_2) + p(P_2) + (n\gamma, e^+e^-)$$

is considered. The enhancement by the so called large logarithm  $L \equiv \ln(Q^2/m_e^2)$  and by the logarithm of the experimental cut-off parameter on the final electron energy make the size of the one-loop correction to be of the order of a few percent.

Using the parameterization of vacuum polarization by F. Jegerlehner [5], we have shown, see Fig. 1, that the contributions of muons and hadrons have to be taken into account in addition to the electron-positron ones in the given  $Q^2$  range. As concerning the hadronic contribution to vacuum polarization it can be either treated as a part of radiative corrections or as a part of the proton form factor. To our mind, the former treatment has two advantages. First, this contribution is always there as for point-like as well as for non-point-like particles. Second, in higher order corrections it is not factorized out. Moreover, the effect has a pronounced  $Q^2$  dependence in the explored domain and it certainly affects the extrapolation to the zero momentum transfer point.

Relative QED corrections to the electron line

$$\delta_i = \frac{d\sigma^{(i)}}{d\sigma^{(0)}}$$

are presented in Fig. 2. Index  $i$  runs over:

- a) “2,LLA”, i.e. pure photonic  $\mathcal{O}(\alpha^2 L^2)$  corrections,
- b) “2,NLA”, i.e. the sum of pure photonic  $\mathcal{O}(\alpha^2 L^2)$  and  $\mathcal{O}(\alpha^2 L^1)$  corrections,
- c) “pair”, i.e. the leading and subleading logarithmic pair corrections,
- d) “diff.”, i.e. the shift from the exponentiated one-loop result:

$$\delta_{\text{diff.}} = \frac{d\sigma^{\text{NLO}}}{d\sigma^{(0)}} + \delta_{\text{LLA}}^{(3)} + \delta_{\text{LLA,pair}}^{(3)} + \delta_{\text{LLA}}^{(4)} - \exp\{\delta^{(1)}\},$$

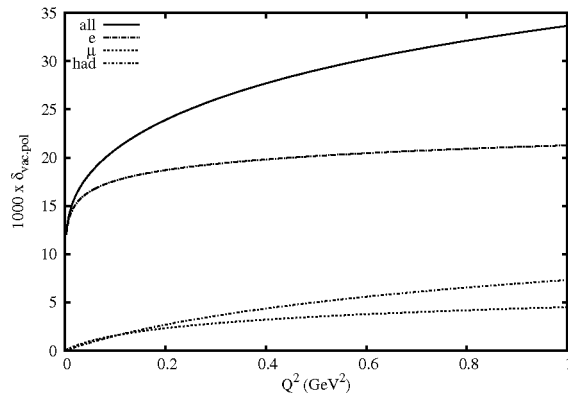

Figure 1: Vacuum polarization corrections due to electrons ( $e$ ), muons ( $\mu$ ), hadrons (had), and the combined effect (all).

where  $\delta^{(1)}$  is the well known first order correction. It is seen from Fig. 2 that the higher order effects are of the order of a few percent in the given experimental set-up. They should be certainly taken into account in the future high-precision experiments. In particular, inclusion of the higher order effects can affect the value of the proton charge radius extracted from the experimental data.

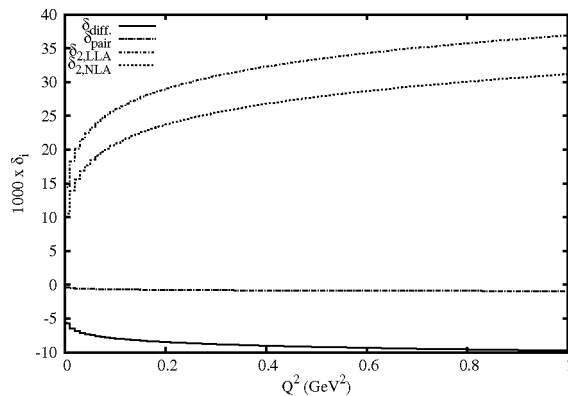

Figure 2: Relative higher order QED corrections to electron line in  $ep$  scattering cross section *vs* momentum transferred squared.

## References

- [1] A.B. Arbuzov, T.V. Kopylova, Eur. Phys. J. C **75**, 603 (2015).
- [2] J. C. Bernauer *et al.* [A1 Collaboration], Phys. Rev. C **90**, 015206 (2014).
- [3] F.A. Berends, W.L. van Neerven and G.J. H. Burgers, Nucl. Phys. B **297**, 429 (1988) [Erratum-ibid. B **304**, 921 (1988)].
- [4] A. Arbuzov and K. Melnikov, Phys. Rev. D **66**, 093003 (2002).
- [5] F. Jegerlehner, Nuovo Cim. C **034S1**, 31 (2011).

# STUDY OF LIGHT NEUTRON DEFICIENT NUCLEI CLUSTER STRUCTURE WITH NUCLEAR TRACK EMULSIONS

D.A. Artemenkov<sup>1</sup>

1. Joint Institute for Nuclear Research, Dubna, Russia

Nuclear track emulsion (NTE) is still retaining its exceptional position as a means for studying the structure of diffractive dissociation of relativistic nuclei owing to the completeness of observation of fragment ensembles and owing to its record spatial resolution. Separation of products of fragmentation and charge-exchange reactions of accelerated stable nuclei make it possible to create beams of radioactive nuclei. A unification of the above possibilities extends the investigation of the clustering phenomena in light radioactive proton-rich nuclei. Conclusions concerning clustering features are based on the probabilities for observing of dissociation channels and on measurements of angular distributions of relativistic fragments.

At the JINR Nuclotron exposures of NTE stacks of (NTE) are performed at energy above 1 A GeV to the beams of isotopes Be, B, C and N, including radioactive ones. In general, the results confirm the hypothesis that the known features of light nuclei define the pattern of their relativistic dissociation. The probability distributions of the final configuration of fragments allow their contributions to the structure of the investigated nuclei to be evaluated. These distributions have an individual character for each of the presented nuclei appearing as their original “autograph”. The nuclei themselves are presented as various superpositions of light nuclei-cores, the lightest nuclei-clusters and nucleons. Recent data on pattern of diffractive dissociation of the nuclei  $^{7,9}\text{Be}$ ,  $^{10}\text{B}$ ,  $^{10,11,12}\text{C}$ , will be discussed in this context.

**ON SOME METHODOLOGICAL AND PHILOSOPHICAL IDEAS OF  
ACADEMICIAN A. M. BALDIN**

A.A. Baldin

*Joint Institute for Nuclear Research, Dubna, Russia*

The role of applied physical variables in construction of physical theories is discussed.

The problem of representation of experimental data for analysis of applicability of theoretical models is considered.

Advantages and disadvantages of the variable  $b_{ik}$  introduced by Acad. A. M. Baldin are discussed.

The ideas of Acad. A. M. Baldin on triangulation in the relative velocities space, development of the ideas of triangulation for description of multiple particle production using the Lobachevsky space are presented.

Acad. A. M. Baldin on the role of symmetry in construction of physical theories and fundamental laws of physical phenomena obtained from experiment.

## OPTIMIZATION OF ACCELERATED CHARGED PARTICLE BEAM FOR ADS ENERGY PRODUCTION

A.A. Baldin<sup>1</sup> A.I. Berlev<sup>1</sup>, M. Paraipan<sup>1,2</sup>, S.I. Tyutyunnikov<sup>1</sup>

1. *Joint Institute for Nuclear Research, Dubna, Russia*
2. *Institute of Space Sciences, Bucharest-Magurele, Romania*

Energy efficiency of proton and ion beams for ADS systems is analyzed with account of energy consumption for accelerators of different types.

The ADS-optimal energy depends on the accelerator type and the type of accelerated ions.

The optimal proton energy for a synchrotron is  $\sim 3$  GeV, for a Linac,  $\sim 1-1.5$  GeV, and for a cyclotron,  $\sim 1$  GeV.

It is demonstrated that for light nuclei, beginning with  ${}^7\text{Li}$ , with energies  $> 1$  GeV/nucleon, ion beams are considerably (several times) more efficient than a proton beam with an energy of 1-3 GeV. The optimal accelerator energy for carbon is 2 GeV/nucleon, while for  ${}^{40}\text{Ca}$  ions, 4 GeV/nucleon.

The possibility of achieving energy release in a quasi-infinite uranium target equivalent to that of 1 GeV protons with higher efficiency (and twice as small accelerator size) in the case of acceleration of light ions is demonstrated.

It is shown that  ${}^7\text{Li}$  beam with an energy of 0.5 GeV/nucleon is equivalent to proton beam with an energy of 2 GeV/nucleon, which allows one to obtain the same energy production with the same or higher efficiency using  ${}^7\text{Li}$  beams and an accelerator with twice as small size. This is especially topical for the accelerator of an ADS fast reactor.

The experimental studies on irradiation of "Quinta" uranium target at extracted carbon beams of Nuclotron demonstrated the promising character of this research; the future experimental studies with proton and light ion beams up to  ${}^{40}\text{Ca}$  in an energy range of 0.5-4 GeV/nucleon are discussed.

# **RELATIVISTICALLY INVARIANT SELF-SIMILARITY APPROACH FOR DESCRIPTION OF COLLECTIVE PHENOMENA**

E.G. Baldina, A.A. Baldin

*Joint Institute for Nuclear Research, Dubna, Russia*

The problem of description of collective phenomena in relativistic nuclear collisions is discussed in the framework of the relativistically invariant self-similarity approach.

Subthreshold cumulative and high  $PT$  particle production in an energy range from 1 to 100 GeV/nucleon, including the range covered by NICA collider is considered.

New experimental data on high  $PT$  particle production in the cumulative conditions obtained at U70 (IHEP) are discussed in the framework of the universal  $A$ -dependence description.

The specific features of enhanced strangeness production in heavy ion collisions (with beam energies around 30 GeV/nucleon) which are assumed to be a signature of nuclear medium phase alteration are described in the framework of the universal self-similarity approach.

Specific features of strange particle production in relativistic ion collisions are studied for various kinematics. The possibility of experimental observation of new collective effects for light and heavy ions in the intermediate energy range is discussed.

## **A DATA SIMULATION MODEL OF THE BM@N GEM DETECTOR**

D.A. Baranov<sup>1</sup>, O.V. Rogachevsky<sup>1</sup>

1. *Joint Institute for Nuclear Research, 6 Joliot Curie St., Dubna, Moscow region, 141980 Russia*

The Gas Electron Multiplier (GEM) detector is one of the basic detector setups of the BM@N experiment (NICA project).

The simulation model that takes into account features of signal generation process in an ionization GEM chamber is presented. Relevant parameters for the simulation were extracted from data retrieved with the help of Garfield++ (a toolkit for the detailed simulation of particle detectors). Due to this, we are able to obtain clusters in layers of the micro-strip readout that corresponds to clusters retrieved from a real physics experiment.

## A SUPERCONDUCTING CW-LINAC FOR HEAVY ION ACCELERATION AT GSI

W. Barth<sup>1,2,5</sup>, K. Aulenbacher<sup>2,4</sup>, F. Dziuba<sup>3</sup>, V. Gettmann<sup>2</sup>, M. Miski-Oglu<sup>2</sup>, H. Podlech<sup>3</sup>,  
S. Yaramyshev<sup>1,5</sup>

<sup>1</sup>GSI Helmholtzzentrum, Darmstadt, Germany

<sup>2</sup>HIM, Helmholtzinstitut, Mainz, Germany

<sup>3</sup>IAP, Goethe University, Frankfurt, Germany

<sup>4</sup>KPH, Johannes Gutenberg-University, Mainz, Germany

<sup>5</sup>National Research Nuclear University - Moscow Engineering Physics Institute, Moscow,  
Russia

Recently the Universal Linear Accelerator UNILAC serves as a powerful high duty factor (25%) heavy ion facility for the ambitious experiment program at GSI. Beam time availability for SHE (Super Heavy Element)-research will be decreased, as UNILAC should provide Uranium beams for FAIR (Facility for Antiproton and Ion Research at Darmstadt) with an extremely high peak current but low duty factor. To keep the GSI-SHE program competitive on a high level and even beyond, a standalone superconducting continuous wave (100% duty factor) linac in combination with the upgraded GSI High Charge State injector is envisaged. In preparation for this, the first linac section (financed by HIM and GSI) since 2016 is under tests with beam, demonstrating the future experimental capabilities. Further on the construction of an extended cryo module, comprising two shorter Crossbar-H cavities, is foreseen to be tested until end of 2017. As a final R&D step towards an entire linac, three advanced modules should be built until 2019, serving for first user experiments at the Coulomb barrier.



## KINEMATICAL FIT AND CHANNELS SEPARATION AT THE *np*-EXPERIMENTS AT JINR

A. Belyaev, A. Jerusalemov, F. Kotorobai, V. Pechenov, V. Richvitsky, A. Troyan

The method of channels separation in particle-particle collisions are presented. The kinematical fit and weights for track combinations are used. The Kolmogorov criterion is applied to check agreement between experimental and theoretical  $\chi^2$ -distributions. Investigations were made with data of *np*-experiment in the VBLHEP (Dubna) and *pp*-collisions in GSI (Darmstadt).

# RADIAL FLOW IN NON-EXTENSIVE THERMODYNAMICS AND STUDY OF PARTICLE SPECTRA AT LHC IN THE LIMIT OF SMALL ( $q - 1$ )

Trambak Bhattacharyya<sup>1,2†</sup>, Jean Cleymans<sup>2</sup> Arivnd Khuntia<sup>1</sup>, Pooja Pareek<sup>1</sup> and  
Raghunath Sahoo<sup>1</sup>

(1) *Discipline of Physics, School of Basic Sciences, Indian Institute of Technology Indore,  
M.P. 452020, India.*

(2) *UCT-CERN Research Centre and Department of Physics, University of Cape Town,  
Rondebosch 7701, South Africa*

† *E-mail: trambak.bhattacharyya@uct.ac.za*

It is now a standard practice to use the Tsallis distribution [1] for describing the transverse momentum distributions at high energies [2, 3, 4, 5]. The Tsallis distribution is given by:

$$f = \left[ 1 + (q - 1) \frac{E - \mu}{T} \right]^{-\frac{1}{q-1}}. \quad (1)$$

where  $q$  is the Tsallis parameter and in the limit  $q \rightarrow 1$ ,  $f$  tends to exponential Boltzmann like distribution. Using a thermodynamically consistent Tsallis distribution,  $f^q$  [6], The expressions for entropy density particle number density energy density and the pressure in terms of Tsallis distribution can be found in [7]. In all fits to transverse momentum spectra, the parameter  $q$  turns out to be very close to 1 [8, 9] and hence we expand the Tsallis distribution in a Taylor series of powers of  $(q - 1)$  (see [10, 11] for similar approaches). This helps in studying the degree of deviation of transverse momentum spectra and other thermodynamic quantities from a thermalized Boltzmann distribution. The modified Tsallis distribution,  $f^q$ , appearing in the expressions for the thermodynamic quantities can be expanded in a Taylor series in  $q - 1$  with the following result:

$$\begin{aligned} & \left[ 1 + (q - 1) \frac{E - \mu}{T} \right]^{-\frac{q}{q-1}} \simeq e^{-\frac{E-\mu}{T}} \left[ 1 + (q - 1) \frac{1}{2} \frac{E - \mu}{T} \left( -2 + \frac{E - \mu}{T} \right) \right. \\ & + \frac{(q - 1)^2}{2!} \frac{1}{12} \left( \frac{E - \mu}{T} \right)^2 \left\{ 24 - 20 \frac{E - \mu}{T} + 3 \left( \frac{E - \mu}{T} \right)^2 \right\} + \mathcal{O} \{ (q - 1)^3 \} + \dots \end{aligned} \quad (2)$$

After checking thermodynamic consistency, we provide analytical results for the Tsallis distribution in the presence of collective flow up to the first order of  $(q - 1)$  [12].

$$\begin{aligned} \frac{1}{p_T} \frac{dN}{dp_T dy} &= \frac{gV}{(2\pi)^2} \left\{ 2T[rI_0(s)K_1(r) - sI_1(s)K_0(r)] - (q - 1)Tr^2I_0(s)[K_0(r) + K_2(r)] \right. \\ & + 4(q - 1)TrsI_1(s)K_1(r) - (q - 1)Ts^2K_0(r)[I_0(s) + I_2(s)] \\ & + \frac{(q - 1)}{4}Tr^3I_0(s)[K_3(r) + 3K_1(r)] - \frac{3(q - 1)}{2}Tr^2s[K_2(r) + K_0(r)]I_1(s) \\ & \left. + \frac{3(q - 1)}{2}Ts^2r[I_0(s) + I_2(s)]K_1(r) - \frac{(q - 1)}{4}Ts^3[I_3(s) + 3I_1(s)]K_0(r) \right\} \quad (3) \end{aligned}$$

The formula is compared with the experimental data.

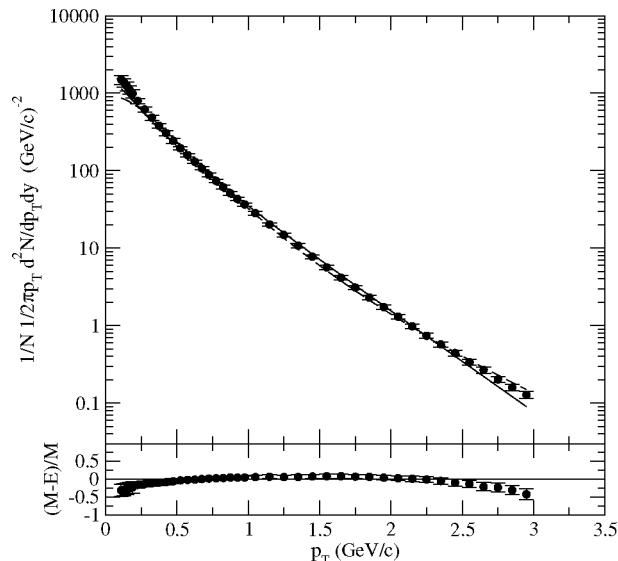

Figure 1: Fits to the normalized differential  $\pi^-$  yields as measured by the ALICE collaboration in  $(0 - 5)\%$  Pb-Pb collisions at  $\sqrt{s_{NN}} = 2.76$  TeV [5]. The fit with the Tsallis distribution including flow keeping terms to first order in  $(q - 1)$  (dashed line). The flow velocity is fixed at  $\beta = 0.609$ , with  $T = 146$  MeV,  $q = 1.030$  and the radius of the volume is  $R = 29.8$  fm. The solid line is the Tsallis distribution without flow. The lower part of the figure shows the difference between model (M), i.e. Tsallis with flow up to first order in  $(q - 1)$ , and experiment (E) normalized to the model (M) values.

## References

- [1] C. Tsallis, J. Statist. Phys. **52** (1988) 479.
- [2] B. I. Abelev et al. (STAR collaboration), Phys. Rev. C **75** (2007) 064901.
- [3] A. Adare et al. (PHENIX collaboration), Phys. Rev. D **83** (2011) 052004.
- [4] K. Aamodt, et al. (ALICE collaboration), Phys. Lett. B **693** (2010) 53.
- [5] B. Abelev, et al. (ALICE collaboration), Phys. Rev. Letts. **109** (2012) 252301.
- [6] J. Cleymans and D. Worku, J. Phys. G **39** (2012) 025006.
- [7] J. Cleymans and D. Worku, Eur. Phys. Jour. A **48** (2012) 160.
- [8] J. Cleymans, G.I. Lykasov, A.S. Parvan, A.S. Sorin, D. Worku, Phys. Lett. B **723** (2013) 351.
- [9] M.D. Azmi and J. Cleymans, J. Phys. G **41** (2014) 065001.
- [10] T. Osada G. Wilk, Phys. Rev. C **77** (2009) 044903.
- [11] W.M. Alberico, A. Lavagno, and P. Quarati, Nucl. Phys. A **680** (2001) 94c.
- [12] T. Bhattacharyya, J. Cleymans, A. Khuntia, P. Pareek and R. Sahoo Eur. Phys. J. A **52**, no. 2, 30 (2016).

## RECENT SELECTED THEORY DEVELOPMENTS FOR NICA

D.B. Blaschke<sup>1,2,3</sup>

1) *Institute of Theoretical Physics, University of Wrocław, Poland*

2) *Bogoliubov Laboratory for Theoretical Physics, JINR Dubna, Russia*

3) *National Research Nuclear University (MEPhI), Moscow, Russia*

The NICA White Paper on «Exploring Strongly Interacting Matter at High Densities» has recently appeared as a Topical Issue in the European Physical Journal A [1]. It comprises 56 articles related to the most prospective physics aspects to be explored at this upcoming facility. I shall present a few selected topics of recent theoretical developments for NICA in which I have been involved.

Within a collaboration involving a team of 9 scientists from Germany, France, Italy, Poland, Russia, Ukraine and the United States we have succeeded to create a startup version for a new Three-fluid Hydrodynamics based Event Simulator Extended by Urqmd final State interactions (THESEUS) and reported about its performance in [2]. In particular, the robustness of the baryon-stopping signal of deconfinement and the occurrence of antiprotons for protons has been investigated for Au+Au collisions in the range of the NICA-MPD energy scan for  $s^{1/2} \sim 6 - 8$  GeV [3]. This signal is reflected also in the flow pattern of light nuclear clusters, in particular deuterons [4]. THESEUS and its underlying three-fluid hydrodynamics model shall be developed further, in particular to be able to improve the description of the hadronization process and capture subtle effects like the «horn» effect for the  $K^+/\pi^+$  ratio which shows a sharp peak at  $s^{1/2} \sim 8$  GeV and to improve the equation of state input.

I shall report the recent progress in developing a generalized Beth-Uhlenbeck approach to a unified description of quark-hadron matter which includes now strangeness and reveals a new mechanism for explaining the  $K^+/\pi^+$  ratio due to the pronounced occurrence of an anomalous mode in the  $K^+$  at finite baryochemical potentials [5]. This approach on the basis of a Polyakov-loop improved Nambu—Jona-Lasinio (PNJL) model can be calibrated to describe the lattice QCD thermodynamics results on the temperature axis of the QCD phase diagram [6]. Aspects of the QCD phase diagram like the possible existence of a critical endpoint of first-order phase transitions [7] will be discussed from the perspective of generalizations of the 3-flavor PNJL model [8] including the conjecture of a universal pressure for the onset of deconfinement in heavy-ion collisions and astrophysics [9].

### References

- [1] D. Blaschke, J. Aichelin, E. Bratkovskaya, V. Friese, M. Gazdzicki, J. Randrup, O. Rogachevsky, O. Teryaev, V. Toneev, «Topical Issue on Exploring Strongly Interacting Matter at High Densities — NICA White Paper», Eur. Phys. J. A52 (8), 267 (2016)
- [2] P. Batyuk et al., arxiv:1608.00965 [nucl-th]
- [3] Yu. Ivanov, D. Blaschke, Phys. Rev. C 92, 024916 (2016); Eur. Phys. J. A52, 237 (2016)
- [4] N.-U. Bastian et al., Eur. Phys. J. A52, 244 (2016)
- [5] A. Dubinin, D. Blaschke, A. E. Radzhabov, A. Wergieluk, arxiv:1608.05383 [hep-ph]
- [6] D. Blaschke, A. Dubinin, L. Turko, in preparation (2016)
- [7] G. Contrera, G. Grunfeld, D. Blaschke, Eur. Phys. J. A52, 231 (2016)
- [8] A. Ayriyan, J. Berdermann, D. Blaschke, R. Lastowiecki, arxiv:1608.07875 [hep-ph]
- [9] D. Alvarez-Castillo et al., Eur. Phys. J. A52, 232 (2016)

# RECENT RESULTS OF AZIMUTHAL ANISOTROPY MEASUREMENTS BY PHENIX

D.S. Blau<sup>1</sup>, for the PHENIX Collaboration

## 1. NRC «Kurchatov Institute»

Azimuthal anisotropy of particle yields in nucleus-nucleus collisions at relativistic energies is an important observable to study collective motion of the dense and hot matter produced in such environments. Recent studies of collisions of small-on-large systems such as p-Au, <sup>3</sup>He-Au, d-Au and Cu-Au showed that collective flow develops even in these collisions if event multiplicity is high. We present the latest PHENIX measurements of flow coefficients  $v_n$  in p-Au, d-Au, <sup>3</sup>He-Au, Cu-Au collisions at  $\sqrt{s_{NN}} = 200$  GeV.

## DATA PROCESSING IN THE MODIFIED SETUP FODS

M.Yu. Bogolyubsky, A.Yu. Bordanovky , A.A. Volkov, D.K. Elumahov, V.P. Efremov,  
A.A. Ivanilov, A.Yu. Kalinin, A.N. Krinitsyn, V.I. Kryshkin, N.V. Kulagin, D.I. Patalakha,  
K.A. Romanishin, V.V. Skvortsov, V.V. Talov, L.K. Turchanovich

*National Research Center «Kurchatov Institute » Institute for High Energy Physics,  
Protvino, Moscow reg., Nauka square 1, 142281, Russia  
e-mail: Mikhail.Bogolyubsky.ihep.ru*

The two-arm setup FODS is designed to study single and pair hadron production in hard processes, as well as cumulative effects in inverse kinematics in the carbon beam of accelerator U-70. In the latter case the channel 22 acts as a spectrometer for forward emitted secondary nuclear fragments (Monte Carlo simulation of this method is given in article [5] in the framework of GEANT4), it identifies and transports them to the setup FODS. The FODS equipment includes a set of scintillation counters, magnet, scintillation hodoscopes, drift chambers, threshold Cherenkov counters, Ring Cherenkov spectrometer (RICH) and hadron calorimeter. In recent years FODS has been undergone modernization with increase more than 3.5 times aperture of the magnet and adding the set of drift tubes, developed in IHEP (Protvino) for experiments at the Large Hadron Collider.

The data processing system of the modified setup includes monitoring of beam intensity, cross-linking of the data and event-builder, reconstruction of tracks in the drift detectors, definition of momentum of charged particles, channel calibration and alignment of the geometry, identification of particles type. The software of mass data processing is designed as program train that goes to the computer cluster IHEP which is gate into the global network of distributed computing GRID. Formation and following movement of the train is supported by the data base of measurements.

Reconstruction of particle trajectories in drift detectors showed the spatial measurement accuracy ( $\sigma \sim 500$  microns for the tubes,  $\sigma \sim 600$  microns for the drift chambers), which corresponds to the results obtained with the optimization of the FODS drift detectors in flow of inclined cosmic radiation. To illustrate operation of the data processing system we show obtained preliminary relative yields of negative particles in pA – scattering at 50 GeV / c in region  $P_t > 0.9$  GeV/c on different targets (beryllium, carbon, aluminum, copper and tungsten), as well as observation forward emitted protons and deuterons in the cumulative region of inverse kinematics in the experiment on CC-scattering at the accelerator U-70.

This work was supported by grant № 16-02-0021 from the Russian Foundation for Basic Research.

# GENERAL SPIN PARTICLE FORMALISM BASED ON SYMMETRY PROPERTIES AND MODEL-INDEPENDENT RESULTS

M. P. Chavleishvili

International University "Dubna", Dubna, RUSSIA

A.M. Baldin suggested new approach in relativistic nuclear physics which is based on the application of the similarity laws, symmetry and other methods, not resting upon the Lagrange functions, to the construction of models starting from the first principles.

We consider the general spin particle formalism based on symmetry properties, including requirements of angular momentum conservation in the t-channel. In such "a dynamic amplitude" approach obligatory kinematic factors arise in helicity amplitudes and consequently in expressions of all observable quantities. Using knowledge about kinematic structure of helicity amplitudes in dynamic amplitude approach we can get: dispersion relations for each individual helicity amplitudes, describing any elastic processes; low-energy theorems (involving reactions with photon, graviton and gravitino); sum rules (including Drell-Hern-Gerasimov SR); model-independent sum--rule type inequalities for observable quantities.

At extremely high energies with fixed angles observables are expressed via dynamic amplitudes with definite kinematical factors. These kinematical factors in the considered region in fact are small parameters in different powers. These parameters suppress contributions of definite helicity amplitudes in observables. In the first approximation such "a kinematic hierarchy" gives us definite relations between observables. For proton-proton scattering we will have relations between asymmetry parameters and even numerical values for them. For the asymmetry parameter  $A_m$  it seems that its observed value just goes up to the obtained asymptotic number.

# MEASUREMENTS AND USAGE OF CROSS-SECTIONS OF VARIOUS (N,XN) THRESHOLD REACTIONS

P. Chudoba<sup>1,2†</sup>, S. Kilim<sup>3</sup>, V. Wagner<sup>1</sup>, J. Vrzalova<sup>1,4</sup>, O. Svoboda<sup>1</sup>, M. Majerle<sup>1</sup>, M. Stefanik<sup>1</sup>, M. Suchopar<sup>1,4</sup>, A. Kugler<sup>1</sup>, M. Bielewicz<sup>3</sup>, E. Strugalska-Gola<sup>3</sup>, M. Szuta<sup>3</sup>

(1) *Nuclear Physics Institute of the ASCR, v. v. i., Rez 130, 250 68 Rez, Czech Republic*

(2) *Charles University in Prague, Faculty of Mathematics and Physics, Ke Karlovu 3, 121 16 Praha 2, Czech Republic*

(3) *National Centre for Nuclear Research, Otwock-Swierk 05-400, Poland*

(4) *Faculty of Nuclear Sciences and Physical Engineering, Czech Technical University in Prague, Brehova 7, 11519 Prague, Czech Republic*

† *E-mail: chudoba@ujf.cas.cz*

Current trend in nuclear physics is a transition from technologies using thermal neutrons to technologies utilizing fast neutrons. Unfortunately long time of focus mainly on the thermal neutrons caused very good knowledge about low energy region and very scarce coverage of the high energy region. This means there is a gap in the knowledge of excitation functions for higher energies. This gap is spreading from 20 MeV up to 1GeV. Which is exactly the energy region needed for description of advanced nuclear systems such as accelerator driven systems(ADS).

Our group is a member of an international collaboration Energy & Transmutation of Radioactive Waste. This collaboration is focusing on ADS for many years. In order to measure neutron field within an ADS models it is necessary to know excitation functions of reactions used to monitor the neutron field. In many cases it has shown that there are almost no experimental data for suitable reactions. Worse and not uncommon case that there are no data at all. Therefore we are also focusing on measurements of these data in order to use them within collaboration as well as to allow further improvements of codes for nuclear data calculations.



# TTH PRODUCTION AT 13 TEV

P.M. Cirkovic<sup>1†</sup>

(1) *University of Belgrade*

† *E-mail: predrag.cirkovic@cern.ch*

In this talk, the latest results of searches for the standard model Higgs boson produced in association with a top quark-antiquark pair ( $t\bar{t}H$ ), where Higgs decays into photons, bottom quark-antiquark pair or leptons via  $WW^*$ ,  $ZZ^*$  and  $\tau\tau$  will be presented. The analyses have been performed using the 13 TeV pp collisions data recorded by the CMS experiment in 2015. The results are presented in the form of the best fit to the signal strength ( $\mu = \sigma/\sigma_{SM}$ ) measured with respect to the Standard Model prediction and its expected and observed 95% CL upper limits.

## References

- [1] CMS Collaboration. CMS-PAS-HIG-16-004, (2016).
- [2] CMS Collaboration. CMS-PAS-HIG-15-005, (2016).
- [3] CMS Collaboration. CMS-PAS-HIG-15-008, (2016).

# THERMAL MODEL DESCRIPTION OF COLLISIONS OF SMALL NUCLEI

J. Cleymans<sup>1†</sup>, B. Hippolyte<sup>2</sup>, H. Oeschler<sup>3</sup>, K. Redlich<sup>4,5,6</sup> and N. Sharma<sup>7</sup>

(1) *UCT-CERN Research Centre and Department of Physics,*

*University of Cape Town, Rondebosch 7701, South Africa*

(2) *Institut Pluridisciplinaire Hubert Curien (IPHC), Université de Strasbourg, CNRS-IN2P3, Strasbourg, France*

(3) *Physikalisches Institut, Ruprecht-Karls-Universität Heidelberg, Heidelberg, Germany*

(4) *Institute of Theoretical Physics, University of Wrocław, Pl-45204 Wrocław, Poland*

(5) *ExtreMe Matter Institute EMMI, GSI, D-64291 Darmstadt, Germany*

(6) *Department of Physics, Duke University, Durham, NC 27708, USA*

(7) *Department of Physics, Panjab University, Chandigarh 160014, India*

† *E-mail: jean.cleymans@uct.ac.za*

The dependence of particle production on the size of the colliding nuclei is analyzed in terms of the thermal model using the canonical ensemble. The concept of strangeness correlation in clusters of sub-volume  $V_c$  is used to account for the suppression of strangeness. A systematic analysis is presented of the predictions of the thermal model for particle production in collisions of small nuclei. The pattern of the maxima in particle ratios of strange particles to pions as a function of beam energy is quite special, as they do not occur at the same beam energy and are sensitive to system size. In particular, the  $\Lambda/\pi^+$  ratio shows a clear maximum even for the smallest systems while the maximum in the  $K^+/\pi^+$  ratio disappears in small systems.

# BARYON ELECTROMAGNETIC FORM FACTORS AT BESIII

Alaa Dbeyssi<sup>1†</sup>  
(on behalf of BESIII collaboration)

(1) *Helmholtz-Institut Mainz*  
† *E-mail: A.Dbeyssi@him.uni-mainz.de*

Electromagnetic form factors are fundamental quantities which parametrise the electric and magnetic structure of hadrons. This contribution reports on the measurements of baryon electromagnetic form factors at the BESIII experiment in Beijing. The Beijing  $e^+e^-$  collider BEPCII [1] is a double-ring symmetric collider running at  $\sqrt{s}$  between 2.0 and 4.6 GeV. Baryon electromagnetic form factors can be measured at BESIII in direct  $e^+e^-$ -annihilation and in initial state radiation processes. Based on the data collected by the BESIII detector at 12 center-of-mass energies between 2.23 and 3.67 GeV, the  $e^+e^- \rightarrow \bar{p}p$  cross section and the time-like proton form factor is measured [2]. Preliminary results from the analysis of the initial state radiation process  $e^+e^- \rightarrow \bar{p}p\gamma$  using a data set of  $7.408 \text{ fb}^{-1}$  collected at center-of-mass energies between 3.773 and 4.6 GeV, are also presented. The cross section for  $e^+e^- \rightarrow \bar{\Lambda}\Lambda$  is measured based on  $40.5 \text{ pb}^{-1}$  data collected at 4 energy points from the threshold up to 3.08 GeV. Preliminary results on the total cross section and the  $\Lambda$  effective form factor are shown. Ongoing analysis based on the high luminosity energy scan from 2015 and from radiative return at different  $\sqrt{s}$  are also described.

## References

- [1] M. Ablikim et al. (BESIII Collaboration), Nucl. Instr. Meth. A **614** 345 (2010).
- [2] M. Ablikim et al. (BESIII Collaboration), Phys. Rev. D **91**, 112004 (2015).

# ANALYSIS OF FRACTAL EVENTS WITH BACKGROUND

T.G. Dedovich<sup>‡</sup> and M.V. Tokarev<sup>‡</sup>

*Joint Institute for Nuclear Research, Dubna, Russia*

*‡ E-mail: tdedovich@yandex.ru*

*‡ E-mail: tokarev@jinr.ru*

## Abstract

Self-similarity and fractality in high energy hadron and nuclear interactions are discussed. The box counting method (*BC*) and the method of the systems of the equations of *P*-adic coverage (*SePaC*) are briefly described. Analysis of simulated fractal events with and without background was carried out by these methods. The procedure to verify the availability of fractal properties in the original data set, to separate fractals and background, to estimate the number of fractals and contamination in the reconstructed data sample was proposed. The *SePaC* method is found to reconstruct all fractal and *BC* - more than 90%. The dependence of contamination of the selected events on the event multiplicity and background is noted. Reconstruction of the spectrum of fractal dimensions is found to depend on the method used and type of background events.

## NUMERICAL MODELING AND ANALYSIS OF THE MAGNETIC FIELD GENERATED BY THE SOLENOID FOR THE SPIN PROGRAM AT NICA

I.Dobrin<sup>1</sup>, A.D. Kovalenko<sup>2</sup>, V. Lagygin<sup>2</sup>, D.Enache<sup>1</sup>, A. Dobrin<sup>1</sup>, I. Popovici<sup>1</sup>

1. *National Institute for Research and Development in Electrical Engineering ICPE-CA, Bucharest*
2. *Joint Institute for Nuclear Reasearch – Dubna*

The first results on the simulation of the magnetic field of the spin rotating superconducting solenoid for NICA is presented. These solenoidal magnets [1] are key elements in the control and manipulation with the polarization of the relativistic protons and deuterons.

For numerical simulations was used Comsol Multiphysics [2], a software package for electromagnetic modeling which is based on the finite element method. Successive improvements to numerical model result in progressively satisfying the requirements imposed through the design theme.

The computational model for the magnetic field problem consists in the solenoid superconducting winding which is enclosed by an air domain. Due the symmetry of the model, for the simulation was used a 2D axial symmetry model.

Through successive simulations were obtained optimized results for the corrections of the magnetic flux density at the ends of the solenoid.

The electrodynamic forces in the winding are also estimated.

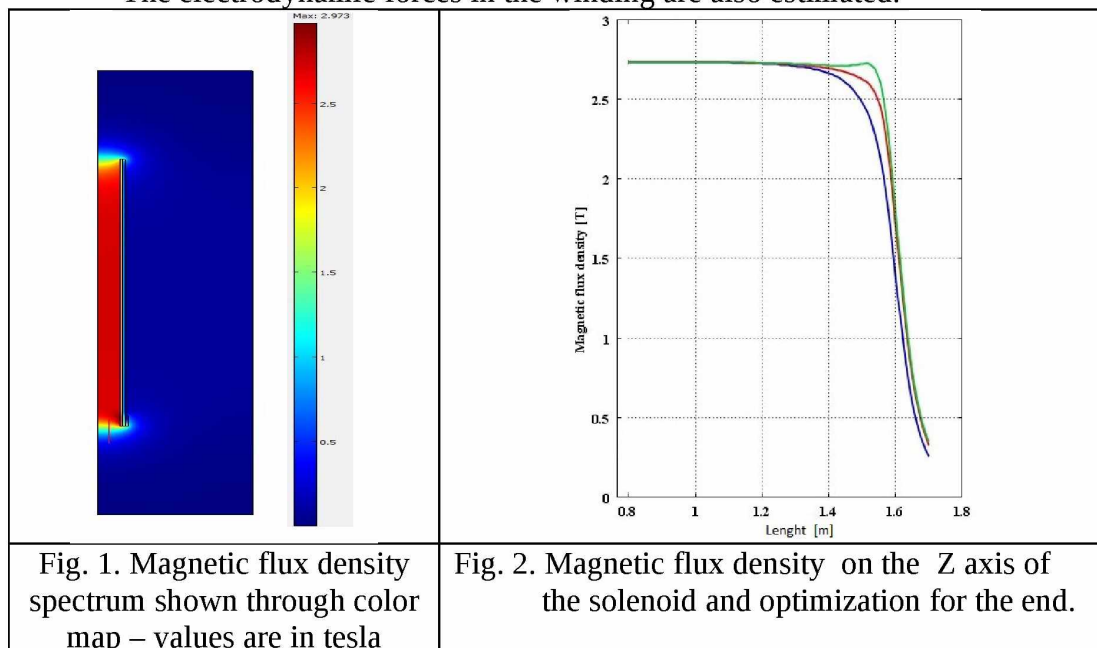

### References

1. A.D.Kovalenko, et all, “*Large superconducting magnets of the NICA complex at JINR*”, 12<sup>th</sup> European Conference on Applied Superconductivity, Lyon, France, sept. 2015.
2. Comsol Multiphysics, [www.comsol.com](http://www.comsol.com)

# A STUDY OF HEAVY EXOTIC BARYON RESONANCES

Yubing Dong<sup>1,2,†</sup> and Qifang Lyu<sup>2,‡</sup>

(1) *Institute of High Energy Physics, Chinese Academy of Sciences, Beijing 100049, China*

(2) *Theoretical Physics Center for Science Facilities (TPCSF), CAS, Beijing 100049, China*

† *E-mail: dongyb@ihep.ac.cn*

‡ *E-mail lvqifang@ihep.ac.cn*

In 2015, two hidden-charm pentaquark resonances  $P_c^+(4380)$  and  $P_c^+(4450)$  were reported by the LHCb collaboration [1]. They are found in the  $J/\psi p$  invariant mass spectrum in the weak decay process of  $\Lambda_b^0 \rightarrow J/\psi p K^-$ . Their masses and widths are

$$\begin{aligned} M_{P_c^+(4380)} &= 4380 \pm 8 \pm 29 \text{ MeV}, & \Gamma_{P_c^+(4380)} &= 205 \pm 18 \pm 86 \text{ MeV}, \\ M_{P_c^+(4450)} &= 4449.8 \pm 1.7 \pm 2.5 \text{ MeV}, & \Gamma_{P_c^+(4450)} &= 39 \pm 5 \pm 19 \text{ MeV}. \end{aligned}$$

At present, it is of great interests to study the nature of these two resonances and many interpretations and approaches were proposed. The two  $P_c$  resonances are also expected to be observed in other facilities, like JLab. We estimated the contributions of the two neutral  $P_c$  resonances in  $\pi^- p \rightarrow J/\psi n$  and predicted the total cross section as well as the differential cross sections for this process. It is expected that the two neutral  $P_c$  states can also be observed in the pion-induced production at J-PARC [2].

Moreover, the strong decays of  $P_c^+(4380) \rightarrow J/\psi p$  and  $P_c^+(4450) \rightarrow J/\psi p$ , under the  $\Sigma_c \bar{D}^*$  molecular ansatz, are calculated with the various spin-parity assignments. According to the present experimental data, our results exclude all the  $P$ -wave  $\Sigma_c \bar{D}^*$  assignments, while allow the  $S$ -wave  $\Sigma_c \bar{D}^*$  scenario for the two resonances. Moreover, the  $J^P = 3/2^-$   $\Sigma_c^* \bar{D}$  and  $\Sigma_c^* \bar{D}^*$  molecular scenarios are also discussed in the heavy quark limit, and we found the  $\Sigma_c^* \bar{D}$  system for the  $P_c(4380)$  is possible [3]. We expect that more experimental information on the spin-parities and partial decay widths and theoretical investigations on other decay modes are needed to clarify the nature of the two hidden-charm pentaquark  $P_c$  resonances.

## References

- [1] R. Aaij *et al.* (LHCb Collaboration), Observation of  $J/\psi p$  Resonances Consistent with Pentaquark States in  $\Lambda_b^0 \rightarrow J/\psi K^- p$  Decays, *Phys. Rev. Lett.* **115**, 072001 (2015), [arXiv:1507.03414 [hep-ex]].
- [2] Q. F. Lyu, X. Y. Wang, J. J. Xie, X. R. Chen and Y. B. Dong, Neutral hidden charm pentaquark states  $P_c^0(4380)$  and  $P_c^0(4450)$  in  $\pi^- p \rightarrow J/\psi n$  reaction, *Phys. Rev. D* **93**, no. 3, 034009 (2016), doi:10.1103/PhysRevD.93.034009, [arXiv:1510.06271 [hep-ph]].
- [3] Q. F. Lyu and Y. B. Dong, Strong decay mode  $J/\psi p$  of hidden charm pentaquark states  $P_c^+(4380)$  and  $P_c^+(4450)$  in  $\Sigma_c \bar{D}^*$  molecular scenario, *Phys. Rev. D* **93**, no. 7, 074020 (2016), doi:10.1103/PhysRevD.93.074020, [arXiv:1603.00559 [hep-ph]].

**EXPERIMENTAL INVESTIGATION OF THE INTERACTIONS THE HIGH ENERGY PROTONS WITH AN EXTENDED PB TARGETS**

V. M. D'yachenko, I. M. Shevtsov

*Joint Institute for Nuclear Research, Dubna*

The analysis of the neutron fluxes generated by protons in the extended Pb targets is given. Energy range of the protons from hundreds MeV to several GeV.

# PROBING THE LOW AND HIGH DENSITY NUCLEAR MATTER BY HADRON SCATTERING

S.M. Eliseev<sup>1</sup>, O.S. Kosmachev<sup>2</sup>

*Joint Institute for Nuclear Research, 141980 Dubna, Russia,*

<sup>1</sup>*E-mail: selis@theor.jinr.ru*

<sup>2</sup>*E-mail: kos@theor.jinr.ru*

Relativistic heavy-ion collisions are considered to be a favorable situation for the study of a large number of different phenomena which are expected to identify new properties of nuclear matter and nuclear interactions predicted by QCD. The interpretation of heavy-ion experiments depends on the comparison with results low energy and from smaller collision systems such as hadron-nucleus. In nuclear collisions, the surface effect is as well present, and also very important [1].

One of the most important subject discussed at present, is the difficulties connected with the long distances in QCD. From QCD we know that at sufficiently density, which may be obtained in high energy nucleus-nucleus collisions, color screening will lead to quark deconfinement. However, nucleons can significantly change their properties even in the ground state of nuclei [2, 3]. As seen in Fig. 1, electron scattering from nuclei shows - the structure of nucleons is modified inside of the nuclear medium. Inclusion of such unconventional EMC-type effects draw greater attention in nuclear physics [2, 3].

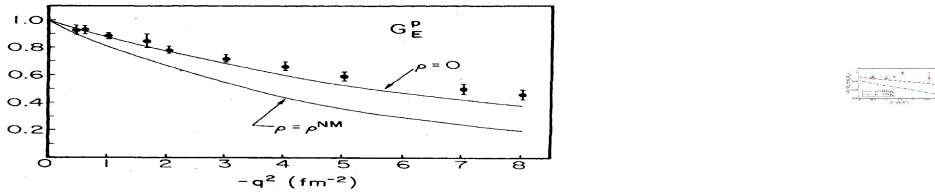

Figure 1:

Left: Calculated values of  $G_E^p(q^2, \rho/\rho^{NM})$  as a function of  $-q^2$  for  $\rho/\rho^{NM} = 0$  (nucleon in vacuum) and for  $\rho/\rho^{NM} = 1$  (nucleon in nuclear matter). Figure is taken from [2], FIG.5. Right: Double ratio for the proton electric/magnetic form factors in  ${}^4\text{He}$ , normalized by the ratio in the vacuum versus the momentum transfer squared,  $Q^2$ . Data are from Mainz (square data point) and Jefferson Lab (circular data points). Predictions are given for normal nuclear matter density ( $\rho = 1.0\rho_0$ ) and half normal nuclear density ( $\rho = 0.5\rho_0$ ). Note the 10% reduction for  $\rho = 0.5\rho_0$  and the 20% reduction for  $\rho = 1.0\rho_0$  at  $Q^2 = 0$ . Figure is taken from [3], FIG.14.



A new Glauber Monte Carlo model for hadron–nuclei interaction at intermediate energy is proposed. We utilized the principal assumptions as in the approaches of others authors describing nuclear collisions at high energy in the framework of the models without QGP. Yet, a number of new ingredients (noneikonal corrections, correlations of nucleons, in the nuclei, the nuclear Fermi motion *etc.*) are introduced.

Comparison of the experimental data with the results of our calculations (see Fig.2) clear demonstrates that the deeply penetrating hadron ( $K^+$ -meson) can "see" in the nucleus some "exotics" (beyond habitual mechanism of nuclear reactions).

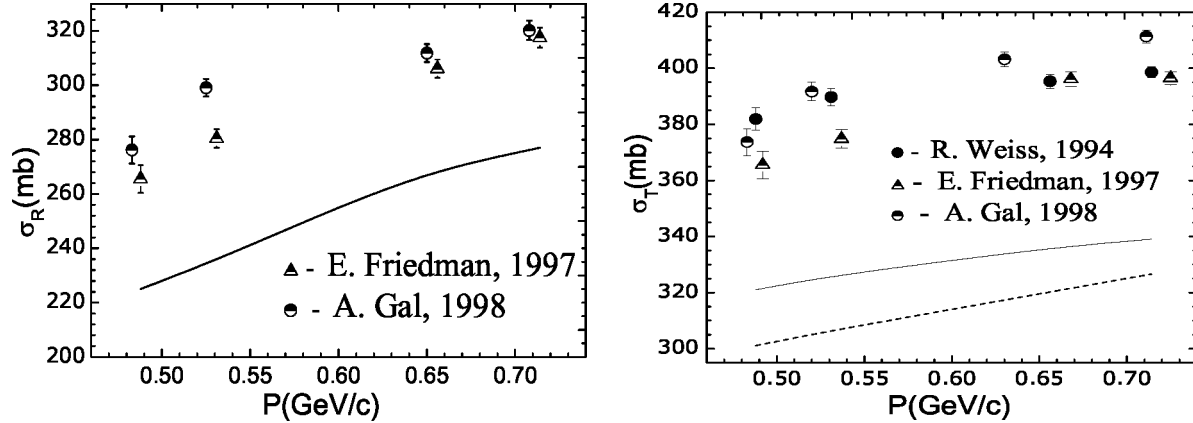

Figure 2:

The calculated and experimental [4-6] total ( $\sigma_T$ ) and reaction ( $\sigma_R$ ) cross sections for  $K^+$ -mesons interaction with  $^{28}\text{Si}$  nuclei versus kaon momentum. The solid lines denote the prediction from our model. The dotted line demonstrates the results from [7].

The results of our work together with [3], Fig.1, represent an important step for the future studies of baryons in high density matter with a strong magnetic field such as in a neutron star, and in heavy ion collision experiments.

## References

- [1] "Nuclear surface effects in heavy-ion collisions at RHIC and SPS", K. Werners, J. Phys. G **32**, S159 (2006).
- [2] "Many-body soliton dynamics: Modification of nucleon properties in nuclei", L. S. Celenza *et al.*, Phys. Rev. C **31**, 232 (1985).
- [3] "Octet baryon electromagnetic form factors in nuclear medium", G. Ramalho, K. Tsushima, and A.W. Thomas, J. Phys. G **40**, 015102 (2013),
- [4] R. Weiss *et al.*, Phys. Rev. C **49**, 2569 (1994).
- [5] E. Friedman *et al.*, Phys. Rev. C **55**, 1304 (1997).
- [6] A. Gal, Nucl. Phys. A **639**, 485c (1998).
- [7] M.F. Jiang, D.J. Ernst and C.M. Chen, Phys. Rev. C **51**, 857 (1995).

## FRAGMENTATION OF $^{16}\text{O}$ PROJECTILE IN NUCLEAR EMULSION AT 60 GEV

M.S.El-Nagdy<sup>1</sup>,A.Abdelsalam<sup>2</sup>,B.M.Badawy<sup>3</sup>,P.I.Zarubin<sup>4</sup>,A.M.Abdalla<sup>5</sup>,  
M.Mahmoud<sup>2</sup>,A.Saber<sup>5</sup> and M.M.Ahmed<sup>1</sup>

1. *Physics Dept. Faculty of Science, Helwan University, Cairo, Egypt.*
2. *Physics Dept. Faculty of Science, Cairo University, Giza Egypt.*
3. *Reactor Physics Dept. Nuclear Research Center, Atomic Energy Authority, Egypt.*
4. *Joint Institute for Nuclear Research, Dubna, Russia.*

*Mathematics and Physics Engineering Department, Faculty of Engineering in Shoubra, Banha University, Cairo, Egypt.*

Topology of  $^{16}\text{O}$  fragmentation at 4.5 A GeV/c with emulsion nuclei is reported. The Projectile fragments of charge  $1 \leq Z \leq 8$  are carefully measured and identified. The experimental measurements of partial production cross-section of the multiple helium fragments emitted from  $^{16}\text{O}$  beam are studied and compared with that obtained from different projectiles and various energies. We present results using a special type of events, selected to separate the events due to collision of singly charged particle  $Z=1$  from  $^{16}\text{O}$  compared with collision of neutron from  $^{16}\text{O}$  beam. Those when neutron from  $^{16}\text{O}$  is collided. We describe a topological structure of such events.

**RELATIVE YIELD OF SECONDARY PARTICLES AND NUCLEAR FRAGMENTS  
IN FORWARD DIRECTION IN 20 A GEV/C CARBON BEAM INTERACTIONS  
WITH NUCLEAR TARGETS**

M.Yu. Bogolyubsky, A.Yu. Bordanovky, A.A. Volkov, D.K. Elumahov, V.P. Efremov,  
A.A. Ivanilov, A.Yu. Kalinin, A.N. Krinitsyn, V.I. Kryshkin, N.V. Kulagin, D.I. Patalakha,  
K.A. Romanishin, V.V. Skvortsov, V.V. Talov, L.K. Turchanovich

*National Research Center «Kurchatov Institute» Institute for High Energy Physics,  
Protvino, Moscow reg., Nauka square 1, 142281, Russia  
e-mail: Dmitriy.Elumahov@ihep.ru*

Relative yields of  $\pi^\pm$ ,  $k^\pm$ , protons, antiprotons and nuclear fragments were measured in 20 A GeV/c carbon beam interactions with carbon and lead targets at the IHEP accelerator U-70. One of the channels acts as a spectrometer for forward emitted secondary particles and nuclear fragments. Measurements were made at production angles of secondaries from 0 up to 6 milliradians with rigidity (p/q) from 7 to 60 GeV/c.

This work was supported by grant № 16-02-0021 from the Russian Foundation for Basic Research.

# LORENTZ FORMULAS IN PROJECTIVE TRANSFORMATIONS

N.G. Fadeev<sup>1</sup>

## 1. JINR

Earlier published a new method of getting Lorentz coordinate moving transformations involving the Lobachevsky function  $\cos \theta_L = v/c$  ( $v$  - velocity of the system,  $c$  - speed of light) revealed the geometric connection of the Lorentz formulas with the projective transformations points of one line to another (which are the coordinate axes  $x$  and  $ct$ ).

An interesting physical features can be found from the observed relationship. Lorentz equations relates to the segments of the beam, which performs the projection - "the Lorentz-rays." Their projections on the  $x$ -axis and  $ct$ -axis appear to be the translations suggested by Lorentz in the article published in 1895. The distance between a specific points  $x$  and  $ct$  calculated using the usual (Euclidean) theorem of cosines is an invariant.

Considering that in this approach light speed constancy and its independence from the state of motion of the reference system can be also expressed by the Lobachevsky function, it is possible to conclude that the proposed approach does not disagree with the known principles of relativity, and that there are invariants in the projective geometry, which could be useful for particle physics.

The investigation has been performed in the Laboratory of High Energy Physics, JINR

# **J/ $\psi$ PRODUCTION AT THE STAR EXPERIMENT**

Pavla Federičová<sup>1†</sup> for the STAR collaboration

(1) *Czech Technical University in Prague, Prague, Czech Republic*

† *E-mail: pavla.federicova@fjfi.cvut.cz*

The Relativistic Heavy Ion Collider (RHIC) was built to search for the quark-gluon plasma (QGP) and to study its properties in high-energy heavy-ion collisions. The suppression of J/ $\psi$  production in heavy-ion collisions compared to proton+proton collisions, caused by the color screening of the quark-antiquark potential in the deconfined medium, has been proposed as a signature of the formation of the QGP. However, J/ $\psi$  production rates are also sensitive to other effects such as the cold nuclear matter effects and recombination of uncorrelated charm quark-antiquark pairs. To understand the interplay of these mechanisms, it is important to study J/ $\psi$  production for different collision geometries.

In this talk, I will report recent results on J/ $\psi$  production via the dielectron decay channel (J/ $\psi \rightarrow e^+ + e^-$ ) from the STAR experiment at RHIC in p+p collisions at  $\sqrt{s_{NN}} = 200, 500$  GeV, in d+Au collisions at  $\sqrt{s_{NN}} = 200$  GeV and in heavy-ion collisions, specifically Au+Au collisions at  $\sqrt{s_{NN}} = 200$  GeV and U+U collisions at  $\sqrt{s_{NN}} = 193$  GeV. I will also show results on J/ $\psi$  production measurements via the dimuon decay channel (J/ $\psi \rightarrow \mu^+ + \mu^-$ ) in p+p collisions at  $\sqrt{s_{NN}} = 500$  GeV and in Au+Au collisions at  $\sqrt{s_{NN}} = 200$  GeV using the newly installed Muon Telescope Detector (MTD).

# HEAVY FLAVOR MEASUREMENTS AT THE STAR EXPERIMENT

P. Federic<sup>1†</sup> (for the STAR collaboration)

(1) *Nuclear Physics Institute of the Czech Academy of Sciences*

In ultrarelativistic heavy-ion collisions at RHIC, a new state of nuclear matter with extreme properties is produced – the strongly interacting quark-gluon plasma. Heavy quarks, predominantly produced at early stages of collisions owing to their large masses, provide an exceptional probe for exploring the hot and dense medium created in such collisions.

The Heavy Flavor Tracker (HFT) and Muon Telescope Detector (MTD) have been fully operational since 2014 and have significantly improved STAR's capabilities in measuring both open and hidden heavy flavor hadrons in heavy-ion collisions. We present an overview of recent heavy flavor results obtained at the STAR experiment.

# DRIFT CHAMBERS IN BM@N EXPERIMENT

Ján Fedorišin

(1) *Veksler and Baldin Laboratory of High Energy Physics, Joint Institute for Nuclear Research*  
*E-mail: fedorisin@jinr.ru*

Drift chambers (DCH) constitute an important part of the tracking system of the BM@N experiment designed to study the production of baryonic matter at the Nuclotron energies.

The method of particle hit and track reconstruction in the drift chambers is proposed and tested on the BM@N deuteron beam data.

In first step, the radius vs drift time calibration curve is estimated and applied to calculate DCH hit closest approach coordinates. These coordinates are used to construct hits in each DCH under the assumption of track linearity. Hits in both the DCHs are subsequently aligned and fitted to produce global linear track candidates. Eventually the hit and track reconstruction is optimized by the autocalibration method. The coordinate resolutions are estimated from Gaussian fits of the DCH hit residual spectra for different DCH planes.

# INITIAL STAGES AND COLLECTIVE EFFECTS IN HADRON COLLISIONS AT THE LHC

G.A. Feofilov<sup>1</sup>

## 1. *Saint-Petersburg State University*

The unexpected observation of long-range azimuthal correlations in pp and pPb collisions, very similar to those observed for large Pb-Pb systems, is one of the puzzling results obtained at the LHC.

These long-range in rapidity and azimuthal correlations, if they exist, should be originated at very early stages of hadron collisions. The natural explanation of processes, preceding the QGP stage, could be considered in the framework of formation and the following hadronization of the quark-gluon strings – color flux tubes stretched between partons of colliding hadrons. In case of sufficiently high densities these strings may overlap and interact. As a result of string fusion, the new kinds of particle-emitting sources (strings with higher tension) may appear, characterized by the growth of mean  $p_T$  of emitted particles and by increased yield of strangeness. Besides, noticeable azimuthal long-range correlations and flows might be also produced as a result of repulsive kind of interaction between certain types of these color-flux tubes (strings).

We present and discuss an overview of independent estimates of a number and density of quark-gluon strings as particle emitting sources, formed at the initial stages, that might be responsible for long-range correlations and major collectivity effects in hadron collisions.

Acknowledgements. This work is supported by the Saint-Petersburg State University research grant 11.38.242.2015.



# TOWARD CENTRALITY DETERMINATION AT NICA/MPD

A.S. Galoyan<sup>1†</sup>, V.V. Uzhinsky<sup>2</sup>

(1) *VBLHEP, Joint Institute for Nuclear Research, Dubna, Russia.*

(2) *LIT, Joint Institute for Nuclear Research, Dubna, Russia.*

† *E-mail: galoyan@lxpub01.jinr.ru*

A key problem of high energy nucleus-nucleus interaction experiments is a centrality determination. We have calculated at various centralities the geometrical properties of nucleus-nucleus interactions (impact parameter distributions, multiplicities of participating nucleons, multiplicities of binary nucleon-nucleon collisions, collision eccentricities) for the energy range ( $\sqrt{s_{NN}}$ ) from 5–10 GeV (NICA/MPD) up to 5 TeV (LHC/ALICE). Our modified version of the Glauber Monte Carlo simulation code [1] has been used for the calculations. A unified systematic of nucleon-nucleon elastic scattering data [2],[3] is in the core of the program. A short description of the code and its results are presented. Using the code, it is shown that the geometrical properties of nucleus-nucleus interactions at the energies 5 – 10 GeV (NICA/MPD) and at energy 200 GeV (RHIC) are quite close to each other. Experimental results obtained at the RHIC Beam Energy Scan show that elliptic flows at the same centralities are close to each other in a wide energy range – from 7 GeV up to 200 GeV. Magnitude of elliptic flow is directly connected with collision eccentricity.

In the second part of our report, we consider a possible determination of centrality at NICA/MPD experiment using calculations of various Monte Carlo event generators. One of the methods of centrality determination is a registration of spectator neutrons from nuclear residuals. It is shown that event generators predict various neutron multiplicities for Au+Au interactions. We undertook special efforts to improve neutron production in the FTF model [4] of GEANT4 toolkit.

## References

- [1] A.S. Galoyan and V.V. Uzhinsky, *Phys. Part. Nucl. Lett.* **12**, 166 (2015).
- [2] V.V. Uzhinsky and A.S. Galoyan, *arxiv:1111.4984[hep-ph]* (2011).
- [3] A.S. Galoyan and V.V. Uzhinsky, *JETP Lett.* **94**, 499 (2011).
- [4] A. Galoyan, A. Ribon and V. Uzhinsky, *JETP Lett.* **102**, 324 (2015).

# THE FERMI COUPLING, THE MASS SPECTRUM AND DECAY CONSTANTS OF MESONS WITHIN THE COVARIANT CONFINED QUARK MODEL

Gurjav Ganbold<sup>1,2†</sup>

(1) *Bogoliubov Laboratory of Theoretical Physics, Joint Institute for Nuclear Research, 141980  
Dubna, Russia*

(2) *Institute of Physics and Technology, 210651, Ulaanbaatar, Mongolia*

† *E-mail: ganbold@theor.jinr.ru*

The ground-state properties of quark-antiquark bound states have been investigated in the framework of the covariant confined quark model. We provide a new insight into the problem of hadron mass definition by employing a master equation which relates the meson mass function to the Fermi coupling  $G$  of the relevant four-fermion interaction, while the compositeness condition  $Z(g) = 0$  for the renormalization constant of the hadron wave function in a Yukawa-type theory (with coupling  $g$ ) guarantees an interpretation of the meson field as a stable bound state of constituent fermions (quarks). First we evaluate  $G$  as a function of the meson mass  $M$  and then, vary the values of the mass and some model parameters so that to obtain a smooth behavior of  $G(M)$  [1]. The conventional meson masses estimated in this manner are found in good agreement with the recent experimental data. Some leptonic decay constants and electromagnetic decay widths of mesons found in [2] have been re-calculated by using the updated parameters. We also have compared the behavior of the obtained  $G(M)$  with the strong QCD coupling  $\alpha_s$  calculated in a QCD-inspired approaches [3].

## References

- [1] G. Ganbold, T. Gutsche, M. A. Ivanov, V. E. Lyubovitskij, *J. Phys. G* **42**, 075002 (2015).
- [2] T. Branz, A. Faessler, T. Gutsche, M. A. Ivanov, J. G. Körner, V. E. Lyubovitskij, *Phys. Rev.* **D81**, 034010 (2010).
- [3] G. Ganbold, *Phys. Rev. D* **81**, 094008 (2010); *Phys. Part. Nucl.* **43**, 79 (2012); *Phys. Part. Nucl.* **45**, 10 (2014).

# NUCLEAR PHOTO-ABSORPTION SUM RULES AND SEARCH FOR EXOTICS

S.B. Gerasimov<sup>1†</sup>

*Bogoliubov Laboratory of Theoretical Physics, JINR, Dubna*

*† E-mail: gerasb@theor.jinr.ru*

Within the non-relativistic approach to photo-absorption sum rules for the 3N(4N)-nuclei [1, 2] new  $\sigma_{-1}$  sum rules proposed which are based on general charge-symmetry (CS) consequences for the "CS-conjugated" triton and  ${}^3\text{He}$  and the "self-conjugated"  ${}^4\text{He}$ . Combining the dispersion GDH-sum rule [3, 4, 5], the isospin-dependent Cabibbo-Radicati sum rule [6], and the relativistic quark dipole-moment-fluctuation sum rule, where three valence quark configurations of the nucleon define the composition of the ground and excited states of the nucleon, the relevant distribution and correlation functions of the quark coordinates in the nucleon ground state are expressed via the experimentally measurable nucleon resonance photo-excitation amplitudes [7]. These functions are used for checking some quantitative features of the quark-configuration structure in the nucleon ground state vector.

## References

- [1] L.L. Foldy, Phys. Rev. **107**, 1303 (1957).
- [2] Yu.K. Khokhlov, Zh.ETF **32**, 124 (1957).
- [3] S.B. Gerasimov, Yad. Fiz. **2**, 598 (1965).
- [4] S.D. Drell, A.C. Hearn, Phys. Rev. Lett. **16**, 908 (1966).
- [5] S.B. Gerasimov, Yad. Fiz. **5**, 1263 (1967).
- [6] N. Cabibbo, L.A. Radicati, Phys. Lett. **B19**, 687 (1966).
- [7] Particle Data Group ( K.A. Olive, et al) Chin.Phys. **C 38**, 090001 (2014).

# VECTOR MESON POLARIZATION VS COLOR TRANSPARENCY

S.R. Gevorkyan<sup>†</sup>

*Joint Institute for Nuclear Research, LHEP*

<sup>†</sup> *E-mail: gevs@jinr.ru*

For many years the vector mesons  $V(\rho, \omega, \varphi, etc)$  electroproduction off nuclei has been considered as an effective tool to study the effect of color transparency (CT) (see e.g. [1]). The idea of CT is that hadron produced in certain hard-scattering processes will have a reduced probability of interaction in nuclear matter due to his smaller size compared with the physical hadron. Manifestation of the CT would be an increase in the value of the nuclear transparency defined as  $Tr = \frac{d\sigma_A}{Ad\sigma_N}$ , where  $d\sigma_A(d\sigma_N)$  is the cross section for the process from nuclei target (free nucleon). The CT effect can be understood within the dipole approach [2], where it is a result of small quark-antiquark dipole interaction with matter [3]. In the hadronic basis this effect is the consequence of Gribov's inelastic screening leading to weakening of interaction in nuclei. On the other hand there is another mechanism of weakening of strong interaction as a result of its dependence on the polarization of vector meson. The vector meson scattering amplitude off nucleon at zero angle averaged over nucleon spin is determined by two quantities:  $\sigma'_T = \sigma_T(1 - i\alpha_T)$  and  $\sigma'_L = \sigma_T(1 - i\alpha_L)$ , where  $\sigma'_{T(L)}$  is the total cross section for interaction of a transversely (longitudinally) polarized vector meson with nucleon and  $\alpha_{T(L)} = Re f_{T(L)}(0)/Im f_{T(L)}(0)$  is the ratio of the real to imaginary part of the corresponding amplitudes at zero angle. The knowledge of these quantities are crucial for different model. For instance the naive quark model predicts  $\sigma_T = \sigma_L$ , whereas the experimental data on electroproduction of  $\rho^0$  mesons off the protons [4] requires that  $\sigma_L(\rho N)/\sigma_T(\rho N) \sim 0.7$ .

Recently we proposed [5] to measure the  $\omega$  mesons photoproduction on a set of nuclei at photons energies  $5GeV \leq E_\gamma \leq 10GeV$  available at Jefferson Lab. We show that incoherent photoproduction of  $\omega$  mesons off nuclear targets is an unique way to get information on the possible dependence of strong interaction on the polarization of vector particle.

Unlike the photoproduction of  $\rho, \varphi$  mesons, which at moderate transfer momenta produced mainly transversely polarized the essential part of  $\omega$ 's in photoproduction are longitudinally polarized [6] due to significant contribution of pion-exchange at considered energy range [4].

From coherent photoproduction one can extract only the transverse cross section  $\sigma'_T(\omega N) = \sigma_T(1 - i\alpha_T)$  as the pion exchange contribution from different nucleons cancels each other leading to photoproduction of only transversely polarized mesons. On the other hand in the incoherent photoproduction off nuclei where the  $\omega$  mesons of both polarizations can be produced one can obtain the important information on longitudinal cross section.

The current quark models [7], [8] predict the considerable difference between total cross sections  $\sigma_L(VN), \sigma_T(VN)$  whose dependence on invariant energy  $W = \sqrt{s}$  is depicted in the fig. 1. The decrease of vector mesons absorption with rising  $Q^2$  in their electroproduction off nuclei commonly interpreted as CT manifestation [9], can be a result of diminished cross section for longitudinally polarized vector mesons as their yield grows with photon virtuality  $Q^2$ . As the CT effect is absent for vector mesons photoproduction at moderate transfer momenta vector mesons production by real photons has an advantage compared

to production by virtual photons.

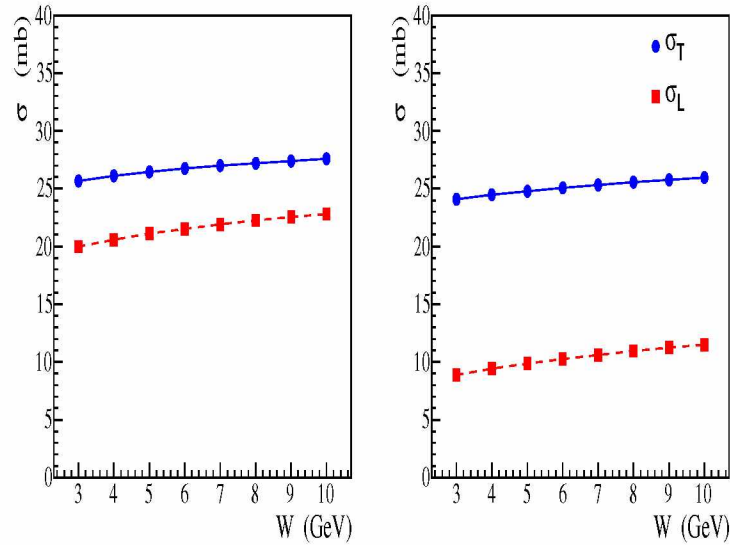

Figure 1: The energy dependence of omega-nucleon total cross sections for different polarizations in approach [7] (left panel) and approach [8](right panel).

## References

- [1] D. Dutta, K. Hafidi , M. Strikman, Color Transparency: past, present and future, arXiv:1211.2826 [nucl-th].
- [2] S. R. Gevorkyan, A. M. Kotzinian, V. M. Jaloyan, Phys. Lett. B **212**, 251 (1988).
- [3] B.Z. Kopeliovich, J. Nemchik , I. Schmidt, Color Transparency at Low Energies: Predictions for JLAB, Phys.Rev.C. **76**, 025210 (2007).
- [4] T. H. Bauer, R. D. Spital, D. R. Yennie, F. M. Pipkin, Rev. Mod. Phys. **50**, 261 (1978).
- [5] E. Chudakov, S. R. Gevorkyan, A. Somov, Phys. Rev. C **93**, 015203 (2016).
- [6] J. Ballam et al., Phys. Rev. D **7** 3150 (1973).
- [7] B. Z. Kopeliovich , J. Nemchik, I. Schmidt, Phys. Rev. C **76**, 015205 (2007).
- [8] J.R. Forshaw, R. Sandapen, Phys. Rev. Lett. **109**, 081601 (2012).
- [9] L. El Fassi et al., Phys. Lett. B **712**, 325 (2012).

# AMPLITUDES RATIOS IN $\rho^0$ LEPTOPRODUCTIONS AND GPDS

S.V. Goloskokov<sup>1†</sup>

(1) *BLTP, Joint Institute for Nuclear Research  
Dubna 141980, Moscow region, Russia*

† *E-mail: goloskkv@theor.jinr.ru*

We investigate exclusive electroproduction of vector and pseudoscalar mesons. These reactions were analyzed within the handbag approach where amplitudes factorize into hard subprocesses and generalized parton distributions (GPDs) which contains information about the hadron structure. Good agreement of our results for the cross sections, and spin observables including spin density matrix elements (SDMEs) with experimental data have been obtained for vector meson production [1].

Using the model results [1] we calculate the ratio of different helicity amplitudes to the leading twist longitudinal amplitude. Such ratios were extracted by HERMES from SDMEs analyses [2]. Comparison of our results with the data [2] shown in Fig. 1 give an additional information about GPDs.

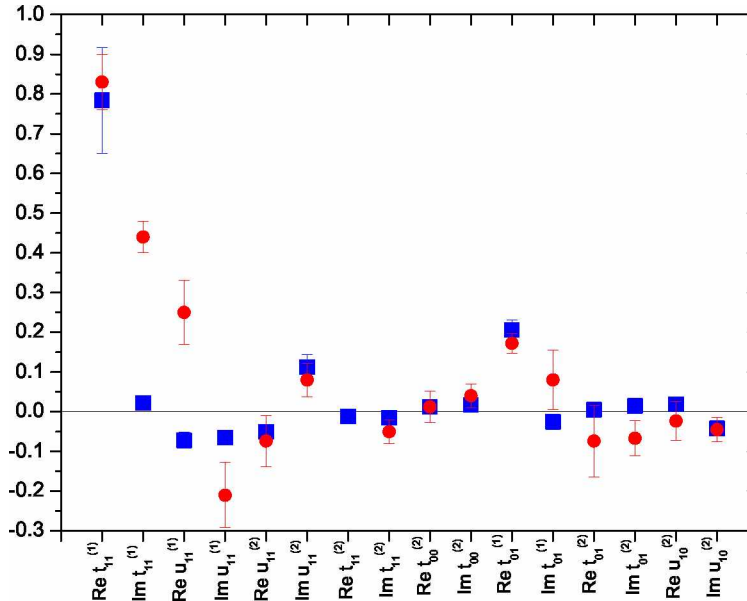

Figure 1: Amplitudes ratio in  $\rho^0$  production. Squares-model results, circles- HERMES data [2].

## References

- [1] S.V. Goloskokov, P. Kroll, Euro. Phys. J. **C50** 829 (2007); ibid **C53** 367 (2008) ; ibid **C59**, 809 (2009); ibid **A47**, 112 (2011); ibid **A50**, 146 (2014).
- [2] A. Airapetian et al (HERMES Collaboration) Euro. Phys. J. **C71**, 1609 (2011).  
S.Manaenkov (HERMES Collaboration), talk at DIS16, Hamburg, 2016, arXiv:1607.02344 [hep-ph].

# NEW STATES OF HADRONIC MATTER FROM THE DATA ON EXCLUSIVE MESON PRODUCTION WITH CLAS/CLAS12

E. Golovach<sup>1†</sup> and CLAS collaboration

(1) *Skobeltsyn Institute of Nuclear Physics, M.V.Lomonosov Moscow State University*

† *E-mail: golovach@jlab.org*

The recent data on the two pion photoproduction off the proton at  $W$  from 1.6 to 2.5 GeV obtained with the CLAS detector at Jefferson Lab are presented. Previously obtained results on the two pion electroproduction at  $Q^2$  from 0.5 to 5.0 GeV<sup>2</sup> allowed us to extract the  $\gamma_v p N^*$  electrocoupling in the framework of the JM phenomenological model for the high lying ( $M > 1.6$  GeV) baryon states. Combined analysis of the preliminary CLAS  $\pi^+\pi^-p$  photo- and electroproduction data demonstrated that for their successful description with  $Q^2$ -independent hadronic parameters of the resonances with masses about 1.7 GeV, the new baryon state  $N(1720)3/2+$  should be implemented. For the first time the mass, the total and, the  $\pi\Delta$  and  $\rho p$  partial decay widths as well as the  $\gamma_v p N^*$  electrocouplings were determined from the CLAS data. The  $N(1720)3/2+$  is the only candidate-state for which the results on the  $Q^2$ -evolution of electrocouplings have become available offering the access to the structure of the new baryon state. New generation of experiments with the CLAS12 detector in the upgraded Hall-B at Jefferson Lab will allow us to study the previously unexplored kinematics of large invariant masses of the final hadron system  $W$  up 3.0 GeV and extend coverage of low photon virtualities down to 0.05 GeV<sup>2</sup>. These studies will be focused on the search for the hybrids baryons which were predicted from the first principles of QCD and contain glue as the structural component. The mass of the low lying hybrids is expected to be in the region from 1.8 GeV to 2.5 GeV. Expected difference in  $Q^2$ -evolution of electrocouplings of regular and hybrid baryons will provide a signature for the hybrid states. The search for the hybrid states will be performed in both  $p\pi^+\pi^-$  and  $K^+Y$  electroproduction channels.

# THE STUDY OF $B - S$ ANOMALY DECAYS IN COVARIANT QUARK MODEL

A. Issadykov

*BLTP, JINR*

We performed the straightforward calculation of the  $B \rightarrow S$  ( $S$  is a scalar meson) transition form factors in the full kinematical region within the covariant quark model. It is estimated impact of decay  $B \rightarrow K_0^*(\rightarrow K\pi)\mu^+\mu^-$  to  $B \rightarrow K^*(\rightarrow K\pi)\mu^+\mu^-$  decay.

Calculated branching fractions and polarization observables in the cascade decay  $B_S \rightarrow \phi(\rightarrow K^+K^-)\mu^+\mu^-$ . We compare the obtained results with available experimental data and the results from other theoretical approaches.



# INVESTIGATION OF REACTIONS USING POLARIZED AND UNPOLARIZED DEUTERON BEAM AT NUCLOTRON: CURRENT STATE AND PERSPECTIVES

M. Janek<sup>1†</sup>, V.P. Ladygin<sup>2</sup>, S.M. Piyadin<sup>2</sup>, Yu.V. Gurchin<sup>2</sup>, A.Yu. Isupov<sup>2</sup>, J.-T. Karachuk<sup>3</sup>, A.N. Khrenov<sup>2</sup>, A.K. Kurilkin<sup>2</sup>, P.K. Kurilkin<sup>2</sup>, N.B. Ladygina<sup>2</sup>, A.N. Livanov<sup>2</sup>, G. Martinska<sup>4</sup>, S.G. Reznikov<sup>2</sup>, G. Tarjanyiova<sup>1</sup>, A.A. Terekhin<sup>2</sup> and I.E. Vnukov<sup>5</sup>

(1) *Physics Department, University of Zilina, Univerzitna 1, 01001 Zilina, Slovakia*

(2) *Joint Institute for Nuclear Research, Joliot-Curie 6, 141980 Dubna, Moscow region, Russia*

(3) *Advanced Research Institute for Electrical Engineering, Splaiul Unirii 313, Bucharest, Romania*

(4) *Institute of Physics, University of P. J. Shafarik, Park Angelinum 9, 04001 Kosice, Slovakia*

(5) *Belgorod State University, Pobedy 85, 308015 Belgorod, Russia*

† *E-mail: janek@fyzika.uniza.sk*

Intensive theoretical and experimental investigations of short range correlations of nucleons in nuclei have been performed during last decade. The main goal of the DSS project is to investigate the spin structure of nucleon-nucleon and three nucleon short-range correlations via the measurements of the polarization observables in the deuteron induced reactions at intermediate energies at Nuclotron. Deuteron induced reactions at intermediate energies have been investigated at Internal Target Station (ITS) [1] of Nuclotron. In this framework,  $dp$  non-mesonic breakup and  $dp$  elastic scattering reactions are investigated at intermediate energies at ITS which is very well suited for these measurements. Some of presented results of differential cross sections and analyzing powers of  $dp$  elastic scattering are compared with theoretical predictions based on relativistic multiscattering model. The data have been accumulated in the angular range ( $70^\circ - 120^\circ$ ) in c.m up to deuteron energy of 2000 MeV. The  $dp$  breakup data are obtained with the detection of two outgoing protons at the angles of ( $19^\circ - 54^\circ$ ) in lab. frame at the deuteron energies from 300 MeV to 500 MeV. Results are compared with with MC simulation performed in geant4 toolkit.

Nuclear matter can be considered as the cold dense drops [2] with density five times larger than density in the centre of nucleon. One of the tools to study spin structure of short range correlations is the measurements of the cross section, tensor analyzing power  $T_{20}$  and spin correlation parameter  $C_{y,y}$  in the  $d^3He \rightarrow p(0^\circ)^4He$  reaction [3] at the energies between 1000 and 1750 MeV using polarized  $^3He$  target [4] and extracted polarized deuteron beam from new polarized ion source [5] at Nuclotron. For this purposes the feasibility study based on MC simulation has been performed. Proposed experiments on extracted deuteron beam of Nuclotron is aimed to investigate: non-nucleonic degrees of freedom and baryonic resonances properties in the  $d(A,d(0^\circ))X$  and  $d(A,\pi-(0^\circ))X$  reactions at different energies, non-nucleonic degrees of freedom via the measurements of the tensor  $A_{yy}$  and vector  $A_y$  analyzing powers in  $d(A,\pi-)X$  reaction and polarization properties of the baryonic resonances in the  $d(A,d)X$  reaction and others.

## References

- [1] A.I. Malakhov et al., Nucl. Instr. Meth. in Phys. Res. **A440**, 320 (2000).
- [2] L. Frankfurt, M. Sargsian, M. Strikman, Int. J. Mod. Phys. **A23**, 2991 (2008).
- [3] T. Uesaka et al., Phys. Lett. **B467**, 199 (1999).
- [4] T. Uesaka et al., Nucl. Instr. and Meth. in Phys. Res. **A402**, 212 (1998).
- [5] V.V. Fimushkin et al., Eur. Phys. J. ST **162**, 275 (2008).

**NEW RENORMALIZATION-GROUP REPRESENTATION OF THE  
PERTURBATIVE EXPRESSIONS FOR THE BJORKEN POLARIZED  
SUM RULE AND THE  $e^+e^-$  ANNIHILATION ADLER FUNCTION  
THROUGH THE PT CONFORMAL SYMMETRY BREAKING TERMS:  
THE RESULTS AND POSSIBLE PHENOMENOLOGICAL OUTPUTS**

Andrei Kataev  
*INR RAS, Russia*

A new form of analytical perturbation theory expansion in the massless  $SU(N_c)$  theory, for the non-singlet part of the  $e^+e^-$ -annihilation to hadrons Adler function  $D_{ns}$  and of the Bjorken sum rule of the polarized lepton-hadron deep-inelastic scattering  $CB_{jps}$ , and demonstrate its validity at the  $O(\alpha_s^4)$ -level at least. It is a two-fold series in terms of powers of the conformal anomaly and of  $SU(N_c)$  coupling  $\alpha_s$ . Explicit expressions are obtained for the  $\beta$ -expanded perturbation coefficients at  $O(\alpha_s^4)$  level in  $\overline{MS}$  scheme, for both considered physical quantities. Comparisons of the terms in the  $\beta$ -expanded coefficients are made with the corresponding terms obtained by using extra gluino degrees of freedom, or skeleton-motivated expansion, or  $R\delta$ -scheme motivated expansion in the Principle of Maximal Conformality. Relations between terms of the  $\beta$ -expansion for the  $D_{ns}$ - and  $CB_{jps}$ -functions, which follow from the conformal symmetry limit and its violation, are presented. The relevance to the possible new analysis of the experimental data for the Adler function and Bjorken sum rule is discussed.

# DEVIATION PATTERN APPROACH FOR OPTIMIZING PERTURBATIVE TERMS OF QCD RENORMALIZATION GROUP INVARIANT OBSERVABLES

M. Khellat<sup>1†</sup> and A. Mirjalili<sup>2</sup>

(1) *Independent researcher P.O.B 71968, Shiraz, Iran*

(2) *Physics Department, Yazd University, 89195-741, Yazd, Iran*

† *E-mail: mkhellat@gmail.com*

A QFT perturbative picture constructed upon Feynman diagrams is inevitably accompanied by IR and UV singularities. A sufficient resolution of these divergences could be regulation of loop-integrals, renormalization, and Kinoshita-Lee-Nauenberg (KLN) theorem [1] which, all together, render a whole perturbative description singularity-free by making contributions independently finite at each order. In QED, vacuum polarizations are free of soft singularities while IR and UV singularities can both be tracked down separately in self-energies and vertex corrections through appropriate regulatory techniques. Moreover, in QCD, color confinement adds new complications to the constructed perturbative picture because long-distance phenomena violate the fundamental assumption of perturbative calculations. As a result, either we have to confine ourselves to infra-red safe observables or we would rely on ‘factorization’ to understand the non-perturbative region of QCD based on experimental data or new dynamics which could emerge from possible extensions of QCD. However, even after factorization, the perturbative part must be infra-red safe [2]. The critical point is that, in the above framework, IR singularities are understood on the foundation of a renormalized theory, and therefore these two types of singularities are assumed to be well separated from each other from the beginning. This clear-cut separation is a very important insertion of conventional QCD.

In the context of effective theories, the Appelquist-Carrazone decoupling theorem [3] states that in an arbitrary QFT, one could absorb all logarithmic and positive powers of the energy scale of the theory into the bare parameters of the corresponding effective renormalizable theory. Cancellation of singularities in the conventional perturbative picture by appearing new free parameters such as the renormalization scale or jet parameters [4] does not imply that there would not exist cancellations of finite contributions among different orders. For instance, a truncated renormalization group invariant (RGI) QCD observable, which is an observable expressed in terms of an effective charge [5], do have an explicit dependence even on the free renormalization scale. As a result, optimizing the factorized RGI observable depends on both the method of factorization and renormalization. Here, we first provide some remarks on the two-step strategy for optimization summarized in [6]. This strategy takes advantage of light-front holography to identify a factorization scale and the principle of maximal conformality to choose a renormalization scale. A crucial issue of this optimization program is related to ambiguity of the conformal sector of QCD observables which has been partially discussed in [7]. Finally, we implement the deviation pattern approach [8] in this optimization framework to test the corresponding predictive powers.

## References

- [1] T. Kinoshita, *J. Math. Phys.* **3**, 650 (1962).
- [2] G. Sterman et al., *Rev. Mod. Phys.* **67**, 157 (1995).
- [3] T. Appelquist and J. Carazzone, *Phys. Rev. D* **11**, 2856 (1975).
- [4] G. Sterman and S. Weinberg, *Phys. Rev. Lett.* **39**, 1436 (1977).
- [5] G. Grunberg, *Phys. Lett. B* **95**, 70 (1980).
- [6] S. Brodsky, *J. Few-Body Syst.* **57**, 703 (2016).
- [7] A.L. Kataev and S.V. Mikhailov, *Phys. Rev. D* **91**, 014007 (2015).
- [8] A. Mirjalili and M. Khellat, *Int. J. Mod. Phys. A* **29**, 1450178 (2014)

# HADRON RAPIDITY DISTRIBUTIONS WITHIN A HYBRID MODEL HYDHSD

A.S. Khvorostukhin<sup>1,2†</sup> and V.D. Toneev<sup>1</sup>

(1) *Joint Institute for Nuclear Research, 141980 Dubna, Russia*

(2) *Institute of Applied Physics, Moldova Academy of Science, MD-2028 Kishineu, Moldova*

† *E-mail: hvorost@theor.jinr.ru*

A multistage hybrid model is constructed what joins the initial non-equilibrium stage of interaction, described by the hadron string dynamics (HSD) model, to subsequent evolution of the expanding system treated within ideal hydrodynamics (the second stage). Particles can still rescatter after hydrodynamical expansion that is the third interaction stage. The developed hybrid model is assigned to describe heavy-ion heavy-ion collisions in the energy range of the NICA collider. Generally, the model is in reasonable agreement with the available data on proton rapidity spectra. It is analyzed how within the hybrid model, the form of proton rapidity distributions depends on the start/finish time of the hydrodynamic evolution. Reproducing proton rapidity spectra, our hybrid model cannot describe the rapidity distributions of pions underestimating systematically the pion yield. The model should be improved by taking into consideration viscosity effects at the hydrodynamical stage of system evolution.

## COMPARISON OF NEUTRON INDUCED FISSION AND CAPTURE IN NP-237 AND PU-239 IRRADIATED IN QUINTA ASSEMBLY WITH 660 MEV PROTON BEAM

S. Kilim<sup>1</sup>, M. Szuta<sup>1</sup>, E. Strugalska-Gola<sup>1</sup>, M. Bielewicz<sup>1</sup>, S. I. Tyutyunnikov<sup>2</sup>, V. I. Stegailov<sup>2</sup>

For the collaboration “Energy and Transmutation of RAW”

<sup>1</sup> National Centre for Nuclear Research, 05-400 Otwock-Swierk, Poland

<sup>2</sup> Joint Institute for Nuclear Research, 141980 Dubna, Russia

E-mail: stanislaw.kilim@ncbj.gov.pl

Results of Np-237 and Pu-239 transmutation investigation are presented. The samples were irradiated in spallation neutrons produced in ADS setup QUINTA on purpose to determine number of fissions and captures. The accelerated beam consisted of protons of energy 600 MeV. A gamma-ray spectrometry method was used.

During analysis of the Np-237 spectra several fission products and one actinide were identified. Much more fission products were identified in Pu-239 sample. The identified gamma lines and adequate isotopes are listed in the presentation.

The fission product activities gave the number of fissions, both in Np-237 and Pu-239. Activity of the actinide Np-238, a result of neutron capture by Np-237 gave the number of captures. The method failed for determination of captures in Pu-239.

# HADRONIC RESONANCE PRODUCTION WITH ALICE AT THE LHC

Sergey Kiselev for the ALICE collaboration

*Institute for Theoretical and Experimental Physics, Moscow, Russia*

Hadronic resonance production plays an important role both in elementary and in heavy-ion collisions. In heavy-ion collisions, the medium at high density and/or high temperature can modify the properties of short-lived resonances such as their masses, widths and spectral shapes. Moreover, since the lifetimes of short-lived resonances are comparable with the time span of the late hadronic phase, regeneration and rescattering effects become important and resonance ratios to longer lived particles can be used to estimate the time interval between the chemical and kinetic freeze-out. The measurements in pp and p-Pb collisions constitute a reference for nuclear collisions and provide information for tuning event generators inspired by Quantum Chromodynamics. In this talk we present recent results on short-lived hadronic resonances obtained by the ALICE experiment in pp, p-Pb and Pb-Pb collisions at the LHC energies. The ALICE results on transverse momentum spectra, yields and their ratio to long-lived particles, and nuclear modification factors will be discussed. The results will be compared with model predictions and measurements at lower energies.



## MODIFICATION OF THE STRANGE MESON PROPERTIES IN NUCLEAR MATTER

Yu.T.Kiselev<sup>1</sup>, M.Hartmann<sup>2</sup>, E.Ya.Paryev<sup>1,3</sup>, A.Yu.Polyanskiy<sup>1</sup>

1. *Institute for Theoretical and Experimental Physics, Moscow, Russia*
2. *Institute for Nuclear Physics, Forschungszentrum Juelich, Juelich, Germany*
3. *Institute for Nuclear Research, Russian Academy of Science, Moscow, Russia*

The study of kaon and antikaon properties in a strongly interacting environment has been a very active research field over the last two decades, especially in connection with questions of the partial restoration of chiral symmetry in hot/dense nuclear matter and of the existence of a  $K^-$  condensate in neutron stars. It is reasonably well established that the  $K^+$  meson feels a moderately repulsive nuclear potential of about 20–30 MeV at normal nuclear matter density,  $\rho_0=0.16 \text{ fm}^{-3}$ . In contrast, the properties of the  $K^-$  meson in nuclear matter are still the subject of very intense debate. This is due to the complicated dynamics of antikaons inside nuclei, which lead to modifications of their in-medium properties. Current experimental estimates of the depth of the attractive  $K^-$ -nucleus potential vary from -30 to -200 MeV.

To make progress in understanding the properties of the strange mesons with open ( $K^-$ ) and hidden ( $\phi$ ) strangeness in the nuclear medium, the measurements of the production of  $K^+K^-$  pairs with invariant masses corresponding to both the  $\phi$  and non- $\phi$  regions in proton collisions with C, Cu, Ag, and Au targets at an incident beam energy of 2.83 GeV were recently performed by the ANKE Collaboration at COSY. The data from the  $\phi$  region of invariant masses provide information on the momentum dependence of the  $\phi$  nuclear transparency ratio and the in-medium  $\phi$  meson width over the momentum range of 0.6–1.6 GeV/c. Analysis of the data from the non- $\phi$  region of invariant masses, where exclusive differential cross sections for  $K^+K^-$  pair production on the four targets were obtained as functions of the laboratory  $K^-$  momentum, allows to draw the conclusion of the strength of the  $K^-$ -nuclear potential.

# RECENT PROGRESS IN THE EXPERIMENTAL STUDY OF LIGHT NUCLEI PRODUCTION IN Pb+Pb COLLISIONS FROM THE NA49 EXPERIMENT

V.I. Kolesnikov<sup>1</sup>

1. *Joint Institute for Nuclear Research (JINR)*

The study of light nuclei production in relativistic heavy-ion collisions provides a valuable tool to examine the dynamics of strongly interacting matter and final space-time extent of the system at freeze-out. We present final results on transverse momentum spectra and rapidity distributions of deuterons, tritons and helium-3 in central Pb+Pb interaction from the NA49 experiment at the CERN SPS. The measurements at five collision energies cover a large fraction of the phase-space and are unique in exploring the beam-energy dependence of the production rates, particle ratios, cluster population factors, and chemical freeze-out parameters of the source. We discuss the implications of our data in the context of two approaches: final-state coalescence of individual nucleons and thermal statistical mechanism.

# ON THE POSSIBILITY TO OBSERVE THE TRANSITION OF A BARYON PAIR STATE TO A SIX-QUARK CONFINEMENT STATE

V.I. Komarov

*Dzhelepov Laboratory of Nuclear Problems JINR*

The problem of hadron confinement in the nonperturbative regime remains as one of the most urgent and fundamental problems in the framework of the modern Standard Model of strong and electroweak interactions. It suffers from the absence of a coherent theory, and it is difficult to expect serious advances without new experimental information.

One of the methods to obtain such information is the exploration of exotic few-quark systems, such as tetra-, penta- and hexa-quarks. The search for the latter has a long history, but has not yet resulted in any commonly accepted conclusion. A possible reason for this failure may be a disregard of the evident request for an effective transition of a two-baryon system to a six-quark one – a **spacial overlapping** of both three-quark wave functions to create the hexa-quark system. Such an overlap can not be directly reached in any peripheral collision of two nucleons, but the **central NN collision** is a correct way to achieve the overlap.

An apparent obstacle for the overlapping is the short-range repulsion (SRR) in the  $NN$  interaction. This feature is of fundamental importance since it saves the nucleons in the nuclear matter from sticking together after collisions, and the coalescence of the nuclear matter to a dense quark matter. However, the SRR does not create an absolutely hard core at distances less than  $\approx 0.4$  fm. According to modern constituent quark models (e.g.[1]) it creates a repulsive interaction with a finite size potential,  $V(R)$ , depending on the distance,  $R$ , between the centers of the colliding nucleons, so the core is impermeable only at relatively low energies. If the c.m.s. kinetic energy of the colliding nucleons is higher than  $V(0)$ , the nucleons are mutually penetrable and their content in the central collision at  $R=0$  can join. The model calculations give a considerable range of estimates for the  $V(0)$  values at the level of  $\approx 0.5 \div 1.0$  GeV [1,2], which corresponds to a variation of the laboratory beam energy needed to overcome the SRR at values of  $T_{lab}^{min} \approx 1.1 \div 2.5$  GeV. This means that the resonances observed in the  $pp$  collision at 0.7 GeV [3] are of a meson-baryon nature, and in the  $pn$  collision at 1.14 GeV [4] they are at the very threshold of a possible hexa-quark manifestation.

At energies slightly higher than  $T_{lab}^{min}$ , the initial momentum of participating constituent quarks, equal, on average, to  $P_{cms} / 3$ , becomes at  $R = 0$  distance totally expended in the mutual braking of the nucleons. The created hexa-quark system forms an intermediate state  $(6q)^*$  with a nearly doubled baryon density and an excitation energy  $s^{1/2} - 2m_N$ . The system is unstable: it expands in space and loses energy via meson cooling. If at any density and excitation it achieves a confinement structure  $(6q)_{conf}$ , the process acquires a resonance behaviour and the system lives for a time  $1/\Gamma$ , where  $\Gamma$  is a width of the resonance. This quark-structure dibaryon decays to a final  $2N + Mesons$  system. With increase of the initial energy a part of the  $(6q)^*$  system's quarks are ejected and create the leading nucleons in the fragmentation region of the  $pp$  interaction. It excludes the production of any  $(6q)_{conf}$  states. A crude estimation for the energy region favourable for the search for the  $2(3q) \rightarrow (6q)$  transition gives:  $\approx 1 \text{ GeV} < T_{lab} < \approx 20 \text{ GeV}$ . The upper boundary of this interval might be reduced due to the requirement of a definite time interval for the creation of the six-quark confinement structure during the  $3q$  wave function overlap.

Suppression of the background coming from peripheral collisions requires a selection of events with a small relative momentum of the final nucleons emitted at a  $90^\circ$  angle relative the collision axis. The simplest reaction favourable for the proposed objective is  $p + p \rightarrow d(90^\circ) + X$  (or  $p + p \rightarrow \{pp\}_{iso}(90^\circ) + X$ ).  $X$  denotes here a system of mesons, since production of baryon-antibaryon pairs in the energy region of interest is forbidden or strongly suppressed. Inclusive detection of only a deuteron ( or a  $^1S_0$  diproton) includes different channels of the  $6q$ -confinement state decay:  $(6q)_{conf} \rightarrow d + \pi$ ,  $(6q)_{conf} \rightarrow d + 2\pi, \dots, (6q)_{conf} \rightarrow d + n_{max}\pi$ .

A **signature** for the transition of interest may be an **observation of a resonance peak (or peaks)** in the energy dependence of the differential cross section of the deuteron (or  $^1S_0$   $pp$ )  $90^\circ$  emission. The cross section may be chosen to include all channels noted above, or to select a definite region of the pion system invariant masses. Such variation may give additional information on the dynamics of the  $(6q)_{conf}$  decay. The peak(s) observed in the deuteron energy spectra may manifest as low mass resonances reached via the following processes:  $p + p \rightarrow (6q)^* \rightarrow (6q)_{conf} + \pi \rightarrow (d + \pi (or \gamma)) + \pi$ .

Despite many experiments devoted to the study of deuteron production in  $NN$  collisions at intermediate and high energies, no systematic measurements of the process  $p+p \rightarrow d(90^\circ) + X$  in the energy region of interest are known. The nearest data have been obtained in an old experiment [5] on the reaction  $pp \rightarrow d\pi^+$  in the angular interval  $0^\circ$ - $90^\circ$  at beam energies of  $1.45 \div 4.15$  GeV. Its result does not exclude the presence of a bump at  $s^{1/2} \approx 3.1$  GeV with a width of about 0.3 GeV in the energy dependence of the reaction's differential cross section at  $90^\circ$ . The data should be expanded in the energy interval, improved in binning and inclusive of all possible channels of the  $(6q)_{conf}$  decay. The latter is especially important since a relative intensity of the  $(6q)_{conf}$  decay channels is unknown. Future experiments should contain exclusive and polarization measurements.

It should be noted, in conclusion, that studies with a similar motivation may be performed with the processes  $p + n \rightarrow d(90^\circ) + X$  and  $\gamma + d \rightarrow d(90^\circ) + X$ .

#### References

1. A. Valcarce et al., Rep. Prog. Phys. **68** (2005) 965.
2. D. Bartz and Fl. Stancu, Phys. Rev, **C60** (1999) 055207.
3. V. Komarov et al., Phys. Rev. **C93** (2016) 065206.
4. P. Adlarson et al., Phys. Rev. Lett. **112** (2014) 202301.
5. H.L. Anderson et al., Phys. Rev. **D9** ( 1974) 580.

# PHYSICS ARCHITECTURE

N.P.Konopleva<sup>†</sup>

*"VNIIEM" Corporation", Moscow, Russia*

<sup>†</sup> *E-mail: nelly@theor.jinr.ru*

This talk is devoted to the 100th anniversary of General Relativity.

The origin of the basic principles, which define a structure of fundamental physical theories, is under discuss. It is shown in which way the principles of invariance and symmetry become the ground of such theories. Fundamental physical theory axiomatics is clously connected with methods of experimental measurements. Difference between the theories making use global and local symmetries is explained. It is shown that symmetry group localization leads not only to the change of relativity principle, but to the fundamental modification of experimental programs testing the physical theory predictions. It is noted that any fundamental physical theory must be consistent with the measurement procedures employed for its testing. It is just what take place in quantum mechanics. Therefore the conditions which are similar to the Heizenberg uncertainty relation must be formulated in classical mechanics and General Relativity.

# ON THE ROLE OF “GHOSTS” IN THE PHYSICAL INTERPRETATION OF THE UNIVERSE MATTER EVOLUTION

V.M. Koryukin<sup>1†</sup> and A.V. Koryukin<sup>2</sup>

(1) *Mari State University, Yoshkar–Ola*

(2) *Kazan Federal University, Kazan*

† *E-mail: vmkoryukin@gmail.com*

In our works we follow for principles proposed by D.I. Blokhintsev [1] for an explanation of a random character of physical laws. It allows to consider them approximates and to construct the physical theory as the most plausible one. We also follow for Pauli, which introduced a unobservable particle for the production of conservation laws by beta decay. Fermi named it as the neutrino and constructed the theory of the beta decay. We propose to use “ghosts” (unobservable zero-spin fermions) introduced in the quantum chromodynamics for the renormalizability of the theory [2] in the cosmology. The “ghosts” utilization necessity in the Universe is connected with the possibility for an explanation of inflation and processes with an immense energy release. It is quite possibly that “ghosts” have the spin, but which has other qualitative properties, than the spin of observable fermions. Considering “ghosts” as original particles of an Universe matter, whichs are characterized by the  $SU(3)$  symmetry, the transition to leptons (neutrinos and antineutrinos), whichs are characterized by the  $SU(2)$  symmetry, may be considered as the phase transition and may be interpreted as the process, which is connected with the spontaneous breaking of symmetry (we have the freezing-out of freedom degrees). By this a temperature increase caused to the appearance of particles in the excited state, characterized by an availability of charges (quarks and antiquarks, having additional degrees of freedom), among “ghosts”, existing in a ground state. At present quarks and antiquarks attend in hadrons and black holes [3]. In our opinion further it must take place Cooper pairing of noncharged leptons with a formation of a Bose liquid, which must cause to the density reduction of original leptons and to the appearance of photons, fundamental massive vector bosons and charged leptons. In the Universe standard model the given process, having an explosive behavior (Big Bang), is accompanied an energy emission. The appearance of photons (playing the role of standards in the relativity theory) caused to the domination of electromagnetic interactions in experimental data and to the division of the all Universe matter into two subsystems (slow and rapid). The matter of the slow subsystem (a thermostat [1]) does not participate in electromagnetic interactions and play the catalyst role of stochastic processes, which it may observes by the matter of the rapid subsystem. As a result the particles of the rapid subsystem play the role of Brownian particles. They allow to study the properties of slow subsystem particles. For instance the integration of the Heisenberg uncertainty relation allows receiving the rule of the Brownian motion (the square of the deviation from an initial position is the directly proportional to the first degree of the time interval). Of course at present in the Universe it is possible goes the reverse process of the Bose liquid decay with a density increase for noncharged leptons and consequently with the increase of distances between galaxies which is interpreted as the inflation (the effect of the Universe dark energy).

## References

- [1] D.I. Blokhintsev, Printsipinal'nye voprosy kvantovoj mekhaniki ("Nauka", Moskva, 1987).
- [2] F.J. Yndurain, Quantum Chromodynamics: An Introduction to the theory of Quarks and Gluons (New York, Berlin, Heidelberg, Tokyo: Springer-Verlag, 1983). D.I. Blokhintsev, Printsipinal'nye voprosy kvantovoj mekhaniki ("Nauka", Moskva, 1987).
- [3] V.M. Koryukin, On construction methods of the strong gravitation theory. In proceedings of XXII International Baldin Seminar on High Energy Physics Problems: Relativistic Nuclear Physics and Quantum Chromodynamics, September 15-20, 2014 (JINR, Dubna, Russia). 7 p., [http:// pos.sissa.it](http://pos.sissa.it), PoS(Baldin ISHEPP XXII) 024

# SOME NOTES ABOUT THE PROBLEMS OF RELATIVISTIC NUCLEAR PHYSICS

S.M. Eliseev<sup>1</sup>, O.S. Kosmachev<sup>2</sup>

*Joint Institute for Nuclear Research, 141980 Dubna, Russia,*

<sup>1</sup>*E-mail: selis@theor.jinr.ru*

<sup>2</sup>*E-mail: kos@theor.jinr.ru*

It is known that the Standard model (SM) does not describe dark matter and matter in extreme condition. The main reason lies in the fact that here is opens up new physics, i.e. results that cannot be obtained in the framework of known models.

In the description of the observed matter is formed the gap between the lepton and hadron sectors. According to SM leptons and quarks are without structure, but have individual sets of quantum numbers. To specify media data differences not possible. This situation is contrary to the principle cause-and-effect relationships. On the other hand, a holistic description of the lepton sector, developed in recent years, it was found the presence of individual structures of each lepton equation. They acts as carriers of the properties of leptons. It turned out that there is no contradictions to build the structure of quarks and hadrons in the same algorithmic sequence, as the leptons.

The important role in relativistic nuclear physics played two processes: the maximum dissociation, i.e. the formation of the most simple, up to the indivisible components in the collision of relativistic nuclei and self-organization of complex on the basis of simple in the environment, called the matter in extreme condition. The initial phase of extreme States of matter (the protoplasm), on the basis of which the self-organization (i.e., a process inverse decays) intermediate and final objects of observation, may not be in equilibrium condition. Thee Lagrange's method cannot be used in such nonholonomic systems and models based on it become ineffective .

All unstable elementary particles finally decay into the few stable leptons and two non-lepton exceptions, i.e. the photon and protons. This situation naturally raises questions about the possibility of reverse processes associated with the formation of all observed particles on the basis of the few above mentioned. The solution of a set of the mentioned issues is impossible without taking into account the structure of particle on the single relativistic basis.

So the experimental relativistic nuclear physics put multi-tasks. As key priorities it is included the following.

1. The need arose for a consistent description of the lepton and quark structures on the single relativistic basis.

2. The study of structure of the quarks should follow the spirit and meaning of the Dirac algorithm. This includes the description of hadron structure as electrons and other leptons, but taking into account additional symmetries beyond the minimum required for lepton sector.



# ON POSSIBLE CONTRIBUTION OF PARTONS' ORBITAL MOMENTUM TO THE PROTON SPIN

B.F. Kostenko<sup>1†</sup>

(1) *Joint Institute for Nuclear Research*

† *E-mail: bkostenko@jinr.ru*

E. Fermi was the first who understood that electric field surrounding a charged particle and corresponding to virtual photons turns into the real photons after transition into the high-speed reference frame in the limit  $v \rightarrow 1$  [1]. Thus, it was already shown by Fermi and developed further by Weizsäcker and Williams that physical picture of the world may undergo qualitative changes after transition into the infinite momentum frame. On this evidence, it is not strange that the constituent quark model defined in the proton rest frame is not consistent with the helicity content for the current quarks and gluons defined in the moving reference frame in the above mentioned limit. Nevertheless, there is an important differences between the two cases. It is meant in the Fermi-Weizsäcker-Williams (FWW) description that virtual photons do not carry any total angular momentum in the rest frame and they will not carry it after the transformation into the infinite momentum frame too. Conservation of total angular momentum blockades such transformations, although electromagnetic fields containing vortices and carrying longitudinal orbital momentum are well known in paraxial laser optics [2].

According to the EMC measurement of polarized structure functions, the total contribution of quark helicities to the proton spin is small and consistent with zero within the range of experimental errors [3]. Therefore it is natural to suggest on basis of the same angular momentum conservation reason that the deficiency (which persists till now) is hidden in orbital angular momentum of quarks and gluons. Confinement of partons in small transverse spatial regions, seen at high  $Q^2$ , must excite their oscillations along two axes orthogonal to moving direction, which may serve as a source of orbital momentum of partons in the infinite momentum frame. Indeed, coupling of these two oscillations, which is naturally described within Majorana representation of homogeneous Lorentz group [4], leads to vortex excitations which carry nonzero longitudinal orbital momentum. I argue that the so-called proton spin puzzle may be explained by a radical underestimation of the role of the partons' orbital momentum contribution to the proton spin, which occurred at the first stages of the problem study.

## References

- [1] E. Fermi, *Z. Phys.* **29** 315 (1924).
- [2] L. Allen, S.M. Barnett, M.J. Padgett, eds., *Optical Angular Momentum*, IOP Publ., Bristol, 2003.
- [3] EMC, J. Ashman *et al.*, *Phys. Lett.* **B206** 364 (1988).
- [4] F. Gürsey, in "Relativity, Groups and Topology", eds. C. DeWitt, B. DeWitt, New York – London, 1964.

## $\pi^0$ PRODUCTION IN dC- AND dCu-INTERACTIONS AT A MOMENTUM OF 4.5 GeV/c PER NUCLEON

Kh.U. Abraamyan<sup>1,2</sup>, M.A.Kozhin<sup>1</sup>, M.N. Khachatryan<sup>1</sup>,  
A.G. Khudaverdyan<sup>2</sup>, G.L. Melkumov<sup>1</sup>, S.G. Reznikov<sup>1</sup>

1. *VBLHEP JINR, 141980 Dubna, Moscow region, Russia*
2. *Yerevan State University, 0025, Yerevan, Armenia*

We report on measurements of neutral pion production in the inclusive reactions  $d + C \rightarrow \pi^0 + x$  and  $d + Cu \rightarrow \pi^0 + x$  at an incident momentum of 4.5 GeV/c per nucleon. The experiments were performed on the LHE 90-channel lead glass  $\gamma$ -spectrometer. The cross sections were measured over the kinematical region specified by the inequalities  $\theta_\pi \leq 16^\circ$  and  $E_\pi \geq 2$  GeV (in the laboratory frame). The cumulative number and transverse momentum dependences of the exponent  $n$  in the invariant cross section parameterization  $Ed^3\sigma/d^3p \sim A_T^n$  are investigated by comparing of the observed cross sections for  $\pi^0$  production on carbon and copper targets in the intervals  $0.6 \leq X \leq 1.8$  and  $0.04 \leq P_t^2 \leq 0.40$  (GeV/c)<sup>2</sup>. The double-differential cross section for the reaction  $d + C \rightarrow \pi^0 + x$  is measured using statistics of more than 40 000  $\pi^0$  mesons. On the basis of this data we verified the so-called cluster mechanism of  $\pi^0$  production. We have compared our data for the reaction  $d + C \rightarrow \pi^0 + x$ , extrapolated to  $\theta_\pi = 0^\circ$ , with the data from another experiments on pion production:  $d + C \rightarrow \pi^- (0^\circ) + x$  ( $P = 1.75$  and  $2.88$  GeV/c per nucleon) [1];  $p + d \rightarrow \pi^\pm (180^\circ) + x$  ( $P = 8.9$  GeV/c per nucleon) [2];  $d + p \rightarrow \pi^- (0^\circ) + x$  ( $P = 8.9$  GeV/c per nucleon) [3];  $d + C \rightarrow \pi^- (0^\circ) + x$  ( $P = 4.2$  GeV/c per nucleon) [4]. The invariant cross sections for these reactions were approximated by an exponential function  $Ed^3\sigma/d^3p \sim \exp(-X/X_0)$ . The slope parameter  $X_0$  at different kinetic energies of the projectiles in the range of  $1.05 \div 8.0$  GeV per nucleon is determined.

### References

- [1] E. Moeller et.al. – Phys.Rev.C **28** 1246 (1983)
- [2] Baldin A.M. et.al. – JINR 1-82-28
- [3] Anisimov Yu.S. et.al. – YaF **60** 1070 (1997)
- [4] Agakishiev G.N. et.al. – YaF **51** 1591 (1990)

## INVESTIGATION OF PROPERTIES OF $^{238}\text{U}$ , $^{237}\text{Np}$ , $^{239}\text{Pu}$ , and $^{241}\text{Am}$ NUCLEI IN THE KVINTA NEUTRON FIELD AT JINR ACCELERATORS

S. Kilim<sup>1,2</sup>, S.I. Tyutyunnikov<sup>1</sup>, M. Belevich<sup>1,2</sup>, E. Strugalska-Kola<sup>1,2</sup>, M. Szuta<sup>1,2</sup>,  
V. Voronko<sup>1,3</sup>, V. Sotnikov<sup>1,3</sup>, J. Adam<sup>1</sup>, L. Zavorka<sup>1,4</sup>, M. Baznat<sup>1,5</sup>, V.I. Stegailov<sup>1</sup>,  
O. Dalkhzhav<sup>1,6</sup>, I.A. Kryachko<sup>1</sup>, A.A. Smirnov<sup>7</sup>

- 1 Joint Institute for Nuclear Research, Dubna, Russia
- 2 National Centre for Nuclear Research
- 3 NSC “Kharkov Institute of Physics and Technology”, Kharkov, Ukraine
- 4 Czech Technical University, Prague, Czech Republic
- 5 Baznat M.I. Institute of Applied Physics, Academy of Sciences of Moldova
- 6 National University, Ulan-Bator, Mongolia
- 7 Institute of Physical and Engineering Problems, Dubna, Russia

**The experiment** has been performed in the beam from the JINR Nuclotron and in the extracted proton beam with the current of 1  $\mu\text{A}$  and energy of 660 MeV from the Phasotron of the Dzhelapov Laboratory of Nuclear Problems, JINR.

**The goal of the work** is to determine nuclear-physics characteristics of these nuclei, the capture-to-fission cross section ratio, and the cross sections for production of residual nuclei in the targets of  $^{237}\text{Np}$  (Fig. 1),  $^{241}\text{Am}$ , and  $^{239}\text{Pu}$  in the neutron field [1] at the far radius ( $\sim 200$  mm) of the KVINTA uranium ( $^{238}\text{U}$ ) assembly irradiated with 660-MeV protons. At the given point the percentage ratio of the low-energy neutrons is the largest, which allows capture reactions to be separated.

**Gamma spectra** of the irradiated targets were measured at a distance of 100 and 200 mm using an HPGe detector with an efficiency of 30% fabricated at IPTP and a filter (50 mm Pb + 2 mm Cd + 2 mm Cu + 2 mm Al).

**$^{238}\text{U}$ :** -The investigation is concerned with the spectrum of  $^{239}\text{Np}$  (58 h) resulting from a chain of beta decays:

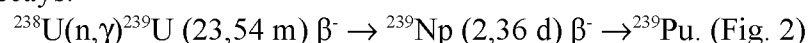

**$^{237}\text{Np}$ :** -Neptunium is one of 15 actinides, produced artificially in power reactor as an energy production byproduct. Np-237 is its longest living isotope with half-life time  $2.144 \cdot 10^6$  y. To get rid of its long lived activity one has to fission it somehow. There's no easy way to do it. There are two channels of neutron interaction with Np-237 – fission and capture – see Fig. 1. Np-237 nucleus fission leads to production of two new isotopes of masses statistically dispersed around two maxima. Some isotopes are produced directly from Np-237 fission (fission product - FP) and the others indirectly, as a result of the other fission product decay. Neutron capture gives  $\beta^-$  active Np-238 nucleus. Formulae show Np-237 fission products production and decay chains identified with gamma lines.

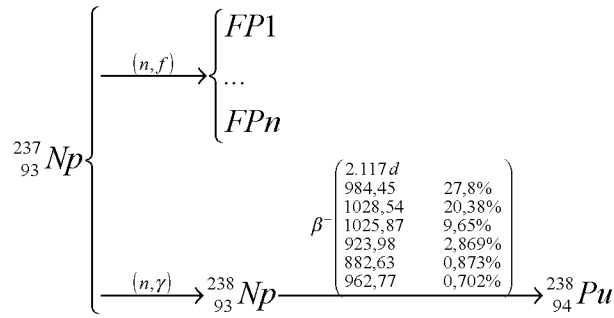

Fig. 1.

As shown on Fig. 1 neutron capture prevails the fission in interaction with neutrons. Especially in thermal region of neutron energy being the most available in present day power reactors. Neutron capture triggers production of other actinides while causing energy loss and affecting neutron balance so much that a fuel campaign gets shorter. There's neutron energy region, approximately above 0.5 MeV, where the Np-237 fission prevails the capture. That's why nuclear power plant has to be based on fast reactors. Another concept of getting rid of long lived activity/actinides is accelerator driven system (ADS) used for incineration.

<sup>239</sup>Pu, <sup>241</sup>Am: -The processing of the data resulted in observing short-lived residual nuclei with a half-life  $T_{1/2} > 5$  min among the products of each target nucleus.

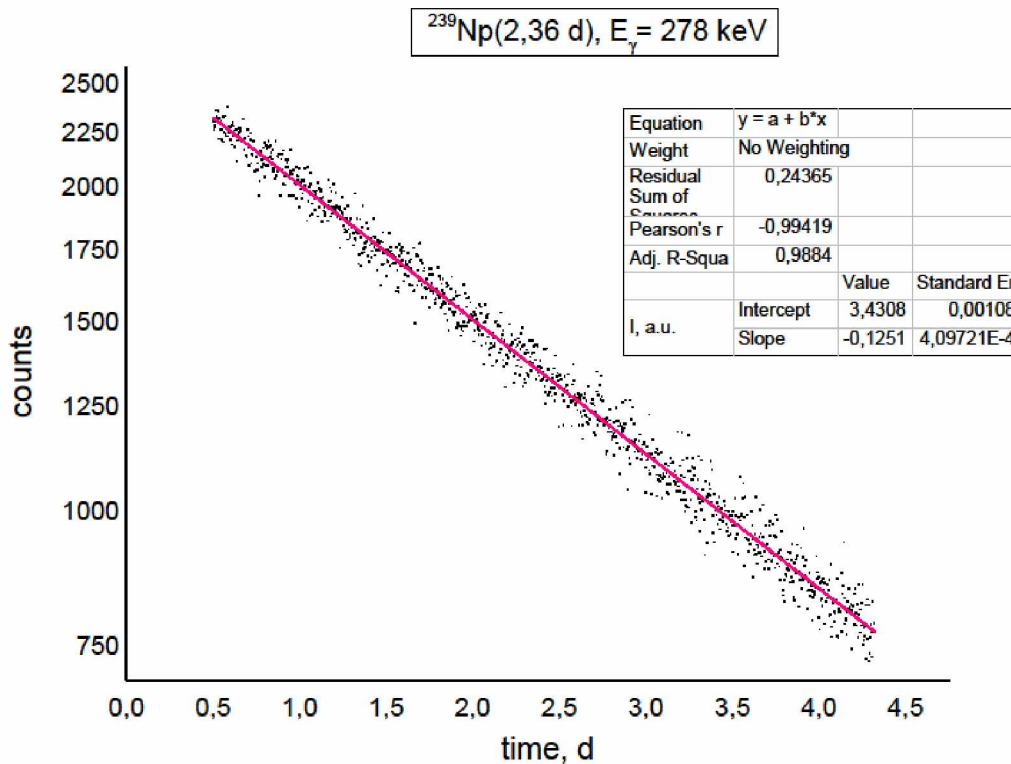

Fig. 2.

References:

1. S.Kilim et al.//XXII Inter. Baldin Seminar, Russia, Dubna, September, 15-22, 2014.

# PROBING COMPOSITE MODELS AT THE LHC WITH EXOTIC QUARKS PRODUCTION

Romain Kukla

*Institut de Recherche sur les lois Fondamentales de l'Univers  
CEA Saclay, 91191 Gif sur Yvette, France  
E-mail: romain.kukla@cern.ch*

The discoveries of the top quark and the Higgs boson, respectively at the Tevatron in 1995 and at the LHC in 2012, crown nearly half a century of building the Standard Model (SM) accordingly to experimental observations (quarks and CP violation for instance). In the perspective of searching new physics beyond the SM (BSM), several scenarii have been tested at the LHC. These searches are motivated by open questions which are not solved in the SM, such as the hierarchy problem and the fine-tuning related to the Higgs boson mass. The description of dark matter is also a very hot subject, leading to multiple searches done by the ATLAS and CMS collaborations. One possible BSM theory, namely the supersymmetry (SUSY), has been studied for more than 40 years and extends the SM in a nice mathematical way by introducing a superpartner to each SM particle, including dark matter candidates. In this talk, I will consider a compelling alternative to SUSY, whose philosophy is completely different, called *compositeness*. It has drawn a lot of interest from the community since composite models can be mapped to extra dimensions such as the Randall-Sundrum theory of warped dimension. The inspiration behind compositeness comes from QCD in which the typical mass range of particles (proton, neutron etc) is around 1 GeV. The spontaneous breaking of the chiral symmetry gives rise to pseudo-Goldstone bosons, the pions, which are well under 1 GeV. In a similar view, if one considers an exotic sector with new massive states above the TeV with a global symmetry  $\mathcal{G}$  broken into  $\mathcal{H}$ , containing the SM groups before EWSB, the Higgs boson can acquire a mass of 125 GeV as the pseudo-Goldstone boson of this symmetry breaking while being part of this exotic sector. The massive SM and exotic states are formed by a linear mixing between elementary states ( $W, B, f$  before EWSB) and composite states. In this *partial compositeness* framework, the Yukawa coupling between the Higgs boson and an elementary state is shown Fig. 1, and depends on the mixing angle between the two sectors.

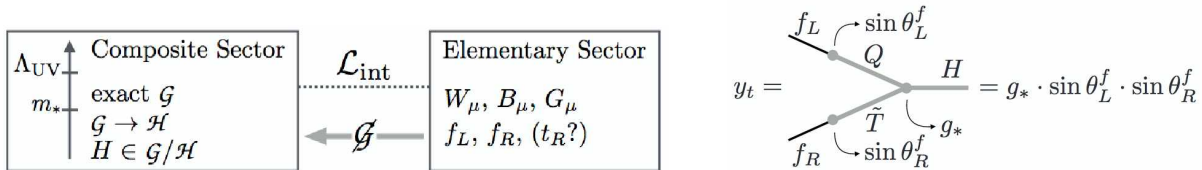

Figure 1: (Left) The two linearly coupled sectors in the composite framework ; (Right) Yukawa couplings in partial compositeness. [1]

The phenomenological interpretation of this strong dynamics is that new heavy quarks should exist around the TeV scale, with a privileged coupling to the top quark - being the heaviest fermion of the SM corresponds to having the largest composite mixing to the exotic sector. These new quarks,  $T, B, T_{5/3}, T_{2/3}, Y_{-4/3}, \tilde{t}$  and so on, decay in  $tV$  or  $bV$

( $V = W, Z, H$ ) and can be produced in pairs by QCD-initiated processes as shown in Fig. 2. There is also a possibility to produce them alone but this process is highly monitored by the coupling strength and thus very model dependent. The ATLAS and CMS collaborations have published several searches for these heavy quarks, usually coined *Vector-like quarks* (VLQ), at 7, 8 and 13 TeV in different channels. The most promising one, for VLQ decaying in tops, is the 2 same-charge leptons one, as illustrated in Fig 2 [2, 3, 4]. Indeed, the SM background is very low, giving a very good opportunity to look for these exotic productions. The 1 lepton + jets channel has given also very tight constraints for VLQ, especially while using boosted techniques [5]. In this talk, I will show a review of searches for these top partners and present also some ways to use 4 tops production.

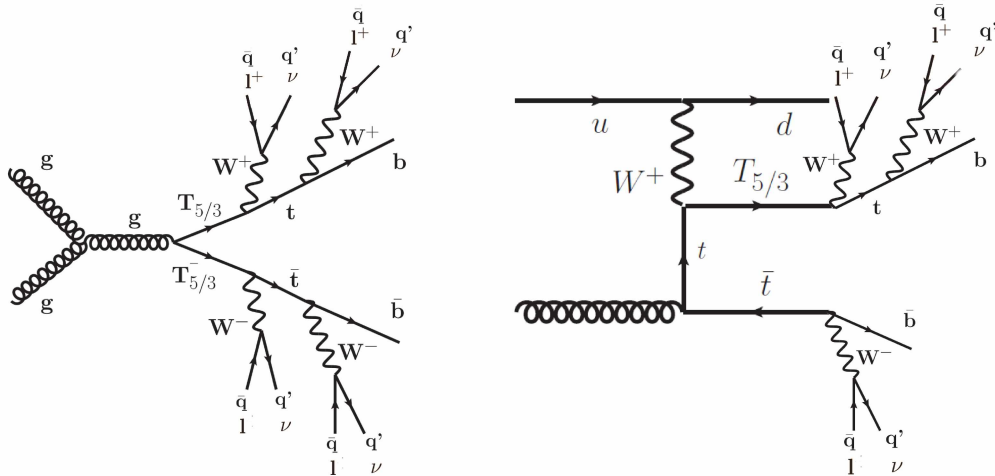

Figure 2: (left) Pair and (right) single productions of the  $T_{5/3}$  in the 2LSS channel.

## References

- [1] G. Panico and A. Wulzer, "The Composite Nambu-Goldstone Higgs", Springer Lecture Notes in Physics, arxiv:1506.01961 (2015).
- [2] ATLAS Collaboration, "Analysis of events with  $b$ -jets and a pair of leptons of the same charge in  $pp$  collisions at  $\sqrt{s} = 8$  TeV with the ATLAS detector", *J. High Energy Phys.*, 10, 150 (2015), CERN-PH-EP-2015-060, ARXIV:1504.04605
- [3] The ATLAS Collaboration, "Search for new phenomena using events with  $b$ -jets and a pair of same charge leptons in  $3.2 \text{ fb}^{-1}$  of  $pp$  collisions at  $\sqrt{s} = 13$  TeV with the ATLAS detector", *ATL-COM-PHYS-2016-036* (2016)
- [4] CMS Collaboration, "Search for top-quark partners with charge 5/3 in the same-sign dilepton final state", *Phys. Rev. Lett.* 112, 171801. (2013), CERN-PH-EP-2013-216
- [5] ATLAS Collaboration, "Search for vector-like  $B$  quarks in events with one isolated lepton, missing transverse momentum and jets at  $\sqrt{s} = 8$  TeV with the ATLAS detector", *Phys. Rev. D* 91, 112011 (2015), CERN-PH-EP-2015-036

# DIGAMMA DIAGNOSTICS FOR THE MIXED-PHASE GENERATION AT NICA

V.I. Kukulín<sup>†</sup> and M.N. Platonova

*Skobeltsyn Institute of Nuclear Physics, Lomonosov Moscow State University,  
Moscow 119991, Russia*

<sup>†</sup> *E-mail: kukulin@nucl-th.sinp.msu.ru*

In the talk we discuss some general features of the novel perspective diagnostic tool for the mixed-phase generation at the new facility NICA planned in JINR.

It is planned that the “mixed” phase produced at the heavy-ion collider NICA will be characterized by rather high density and temperature and also by some admixture of quark-gluon bubbles to hadronic phase. So, the whole program of physical experiments at such conditions will depend upon the exact identification of the state of hot and dense matter emerged from nucleus-nucleus collisions. One can expect that in such collisions a chiral symmetry of QCD (broken at normal conditions) will be partially restored [1, 2, 3, 4]. One of the most distinguished features of such symmetry restoration should be dropping the lightest scalar meson ( $\sigma$ , or  $f_0(500)$ ) mass and thus narrowing its width due to renormalization of the  $\sigma$ -meson propagator in dense nuclear (or hadronic) medium [1, 2, 3, 4]. On the other hand, some QCD-based models [5, 6, 7] predict chiral symmetry restoration even in a single strongly excited hadron (due to decoupling of valence quarks from the  $q\bar{q}$  condensate).

Recently we considered [8, 9] generation of dibaryon resonances in  $NN$  collisions at intermediate energies. Within the above dibaryon model, the dibaryon generation is accompanied with intensive  $\sigma$ -meson production as well. Due to partial chiral symmetry restoration inside the excited dibaryon, we predict some dropping of the  $\sigma$ -meson mass and width already in a single  $NN$  collision. It has been proven both experimentally [10] and theoretically [11] that numerous pion pairs (in the form of  $\sigma$ -mesons) are generated also in high-energy  $pp$  collisions, at 10-200 GeV, at least. So, while propagating through dense and hot hadronic matter, these  $\sigma$ -mesons will undergo further chiral symmetry restoration, and thus their mass and width will drop additionally due to renormalization.

The leading decay mode for the  $\sigma$ -meson is a scalar-isoscalar pion pair. But there is also some  $\gamma\gamma$  decay channel  $\sigma \rightarrow \gamma\gamma$ , the branching ratio of which (related to dipion channel) will depend crucially upon the  $\sigma$  mass and width, which, in turn, depend upon the temperature and average density of matter inside the fireball. Thus one can extract from characteristics of the  $\gamma\gamma$  signal (yield and energy width) very useful information about the basic parameters of the mixed phase emerged in heavy-ion collisions. The first experiments registered  $\gamma\gamma$  signals presumably from  $\sigma$ -meson decay performed at JINR Nuclotron [12] and previously at CELSIUS [13] have given rather encouraging results and clearly shown the possibility of studying  $\gamma\gamma$  signals for diagnostics of hot and dense hadronic matter.

In the talk we discuss some details of the novel diagnostic tool and some characteristics of the  $\gamma\gamma$  signal in view of previous experimental data on the  $\gamma\gamma$  yield in hadronic collisions.

## References

- [1] M.K. Volkov, A.E. Radzhabov, and N.L. Russakovich, Phys. At. Nucl. **66**, 997 (2003) [Yad. Fiz. **66**, 1030 (2003)].
- [2] D.B. Blaschke, G.R.G. Burau, M.K. Volkov, and V.L. Yudin, Eur. Phys. J. A **11**, 319 (2001).
- [3] T. Hatsuda, T. Kunihiro, and H. Shimizu, Phys. Rev. Lett. **82**, 2840 (1999).
- [4] R. Rapp and J. Wambach, Adv. Nucl. Phys. **25**, 1 (2000).
- [5] L.Ya. Glozman, Phys. Lett. **B475**, 329 (2000).
- [6] Yu.S. Kalashnikova, A.V. Nefediev, and J.E.F.T. Ribeiro, Phys. Rev. D **72**, 034020 (2005).
- [7] S.S. Afonin, Phys. Lett. **B639**, 258 (2006).
- [8] M.N. Platonova and V.I. Kukulín, Phys. Rev. C **87**, 025202 (2013).
- [9] M.N. Platonova and V.I. Kukulín, Nucl. Phys. **A946**, 117 (2016).
- [10] D. Alde *et al.* (GAMS Collaboration), Phys. Lett. **B397**, 350 (1997).
- [11] L.S. Kisslinger, W. Ma, and P. Shen, Phys. Rev. D **71**, 094021 (2005).
- [12] Kh.U. Abraamyan *et al.*, Eur. Phys. J. A **52**, 259 (2016).
- [13] M. Bashkanov *et al.*, Int. J. Mod. Phys. A **20**, 554 (2005).



# NUCLEAR PARTON DISTRIBUTIONS

S.A. Kulagin<sup>1†</sup>

(1) *Institute for Nuclear Research of the Russian Academy of Sciences, 117312 Moscow, Russia*

† *E-mail: kulagin@ms2.inr.ac.ru*

The parton distributions of hadrons (PDF) are universal process-independent characteristic of an hadron determining the leading contributions to the cross sections of various hard processes in collision of leptons and hadrons. The deep-inelastic scattering (DIS) and Drell-Yan (DY) experiments with nuclei demonstrated significant nuclear effects on the parton level. These observations rule out the naive picture of the nucleus as a system of quasi-free nucleons and indicate that the nuclear environment plays an important role even at energies and momenta much higher than those involved in typical nuclear ground state processes. The understanding of nuclear parton distributions (NPDF) is particularly relevant for interpretation of the results of high-energy experiments in different fields including DIS with charged leptons and neutrinos, DY process, heavy-ion collisions.

A few approaches to NPDF are available in literature. On a phenomenological level the nuclear correction factors are extracted from global fits to nuclear high-energy data. On a more theoretical level, there are numerous models which are focused on different mechanisms for nuclear corrections. In this contribution we review a microscopic model, which takes into account a number of nuclear effects including nuclear shadowing, Fermi motion and nuclear binding, nuclear meson-exchange currents and off-shell corrections to bound nucleon distributions. The model is successful to describe a number of high-energy nuclear processes including the nuclear DIS with charged leptons [1, 3] and neutrino [2, 5], the DY process in proton-nucleus collisions [4], as well as the  $W^\pm$  and  $Z$  boson production in p+Pb collisions at LHC [6].

## References

- [1] S.A. Kulagin and R. Petti, Nucl. Phys. A **765**, 126 (2006).
- [2] S.A. Kulagin and R. Petti, Phys. Rev. D **76**, 094023 (2007).
- [3] S.A. Kulagin and R. Petti, Phys. Rev. C **82**, 054614 (2010).
- [4] S. A. Kulagin and R. Petti, Phys. Rev. C **90**, 045204 (2014).
- [5] S. A. Kulagin, arXiv:1606.07016 [hep-ph].
- [6] Peng Ru, S.A. Kulagin, R. Petti, Ben-Wei Zhang, arXiv:1608.06835 [nucl-th].

# TEST OF NUCLEAR FRAGMENTATION MODELS WITH CARBON FRAGMENTATION AT 0.3 GeV/n

B.M. Abramov <sup>1</sup>, P.N. Alexeev <sup>1</sup>, Yu.A. Borodin <sup>1</sup>, S.A. Bulychjov <sup>1</sup>, I.A. Dukhovskoy <sup>1</sup>,  
K.K. Gudima <sup>2</sup>, A.P. Krutenkova <sup>1</sup>, V.V. Kulikov <sup>1†</sup>, M.A. Martemianov <sup>1</sup>,  
S.G.Mashnik<sup>3</sup>, M.A. Matsyuk <sup>1</sup>, E.N. Turdakina <sup>1</sup>, A.I. Khanov <sup>1</sup>

(1) *SSC RF ITEP of NRC "Kurchatov Institute", 117218 Moscow, Russia*

(2) *Institute of Applied Physics of Academy of Sciences of Moldova, MD-2028 Chisinau,  
Moldova*

(3) *Los Alamos National Laboratory, Los Alamos, NM 87545, USA*

† *E-mail: kulikov@itep.ru*

Carbon fragmentation at 0.3 GeV per nucleon on Be, Al, Cu and Ta targets has been studied in the FRAGM experiment at ITEP TWA heavy ion accelerator. Momentum spectra of all long lived nuclear fragments from hydrogen isotopes to isotopes of the projectile carbon nuclei were measured with the beamline spectrometer placed at an angle of 3.5 degrees to the beam direction. The fragment momentum spectra span the regions of the fragmentation peaks as well as the cumulative region. The differential cross sections cover up to five orders of magnitude. The obtained data were used for high precision test of a target independence of fragmentation processes in fragmentation peak regions predicted by statistical models. The data were also compared with predictions of few Monte Carlo models of ion-ion interactions: Binary Cascade, INCL++, LAQGSM and QMD. Successes and drawbacks of above mentioned models are discussed.

## STUDY OF NUCLEAR FRAGMENTATION AT MPD/NICA

M.B. Golubeva, A.P. Ivashkin and A.B. Kurepin

*Institute for Nuclear Research, RAS, Moscow*

Due to the much lower beam energy of NICA compared to the RHIC and LHC hadron colliders and the fixed target experiments at SPS the role and performance of the forward detectors of NICA are quite different. The Neutron Zero Degree Calorimeter could be used for the measurement and monitoring of luminosity, however with lower efficiency of neutron detection produced in ultra peripheral collisions. The use of Forward Hadron Calorimeter for the determination of centrality is impossible by simply counting the number of spectators because of the ambiguity of the impact parameter dependence [1]. This ambiguity could be removed if the angular distribution of the spectators will be taken into account [2]. It will be shown in this report by the simulation with LAQGSM that the forward multiplicity detector like V0 of ALICE [3] could not be used for the determination of centrality. However it could provide the valuable information on the nuclear dissociation of heavy ions.

1. Determination of centrality in nuclear collisions by the spectator calorimeter of MPD/NICA, M.Golubeva et al. *Yad. Fiz.* 76 (2013) 2
2. TDR of FHCAL, A.Ivashkin et al. Dubna (2016)
3. Performance of the ALICE VZERO system, ALICE Collaboration, *JINST* 8 (2013) P10016

# SUPERCONDUCTING DIPOLE MAGNET FOR THE CBM EXPERIMENT AT FAIR

P.K. Kurilkin<sup>1†</sup>, A.V. Bychkov<sup>1</sup>, Yu.V. Gusakov<sup>1</sup>, V.P. Ladygin<sup>1</sup>, A.I. Malakhov<sup>1</sup>,  
G. Moritz<sup>2</sup>, P. Senger<sup>2</sup> and A.V. Shabunov<sup>1</sup>

(1) *LHEP-JINR, Dubna, Russian Federation*

(2) *GSI, Darmstadt, Germany*

† *E-mail: pkurilkin@jinr.ru*

The scientific goal of the CBM (Compressed Baryonic Matter) experiment at FAIR (Darmstadt) is to explore the phase diagram of strongly interacting matter at highest baryon densities. The superconducting dipole magnet[1] is a central part of the CBM detector system. A perspective view of the magnet with the support is presented in Fig.1. It is H-type superconducting magnet which will provide a vertical magnetic field with bending power of 1 Tm over a length of 1 m from the target. The results of the JINR participation in the development of the superconducting dipole magnet for the CBM experiment are presented.

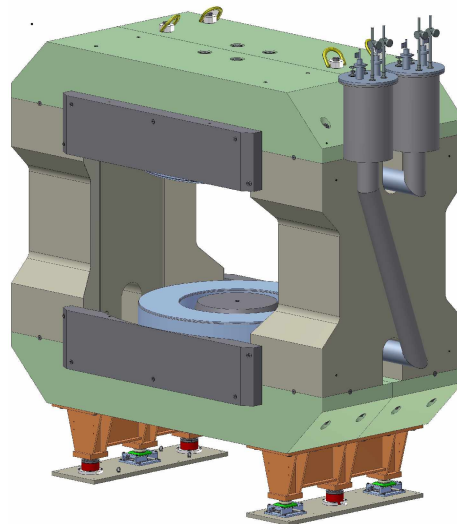

Figure 1: Perspective view of CBM dipole magnet with the support.

## References

- [1] The CBM collaboration, Technical Design Report for the CBM Superconducting Dipole Magnet, Darmstadt 2014.

## COLOUR EVOLUTION IN QCD VACUUM AT LARGE DISTANCES

V.I. Kuvshinov, E.G. Bagashov

*Joint Institute for Power and Nuclear Research – Sosny NAS Belarus*

*220109 Minsk p/o box 119*

*e`mail: kuvshinov2003@gmail.com*

To study the properties of colour particle at large distances we calculate the density matrix of the system colour particle - stochastic QCD vacuum, considered as environment, and averaged over degrees of freedom of the environment. As a result the density matrix of colour particle is depended on the Wilson loop which depends on spanned area  $RT$ .

In the stochastic vacuum Wilson loop decays exponentially with  $RT$  at large distances and we obtain evident form of density matrix of colour particle moving in the stochastic QCD vacuum.

Learning density matrix we obtain characteristics of colour particle: purity (closeness of a quantum state to a pure one), von Neuman entropy, information, fidelity (measure of quantum motion stability). The quantities are calculated for different initial colour states: superposition, pure, mixed, separable, non-separable (entangled), multiparticle.

In the case of of stochastic (not coherent) QCD vacuum (only correlators of the second order are important) in confinement region (Wilson loop decays exponentially) we have decoherence of pure colour states into a mixed white states, while purity decays exponentially (decay rate = string tension). For multiparticles (pure separable, mixed separable and nonseparapable (entangled) states) when  $RT \rightarrow \infty$  we obtain diagonalization of density matrix, decreasing of purity and increasing of von Neumann entropy.

# DELTA EXCITATION IN dp-ELASTIC SCATTERING AT THE INTERMEDIATE ENERGIES

N.B. Ladygina<sup>1†</sup>

(1) *Joint Institute for Nuclear Research*

† *E-mail: nladygina@jinr.ru*

In this report the deuteron-proton elastic scattering reaction is studied in the range of the deuteron kinetic energy from 500 MeV to 1300 MeV. dp-elastic scattering is considered in the relativistic multiple scattering expansion framework since the Faddeev calculation technique is not applicable at these energies. We start from the AGS-equations and iterate them up to a second-order of the nucleon-nucleon interaction. The four contributions are included into consideration: one-nucleon exchange (ONE), single scattering, double scattering, and the term corresponding the delta excitation in the intermediate state. The calculations are performed for the four deuteron energies: 500, 880, 1200, and 1300 MeV. The results are presented in comparison with the experimental data on the dp-elastic scattering cross section.

# INVESTIGATIONS OF COMPRESSED BARYONIC MATTER AT THE GSI ACCELERATOR COMPLEX

V.P. Ladygin<sup>1†</sup> on behalf of JINR part of CBM collaboration

(1) *Joint Institute for Nuclear Research, Dubna, Russian Federation*

† *E-mail: vladygin@jinr.ru*

The scientific mission of the Compressed Baryonic Matter(CBM) experiment is the study of the nuclear matter properties at the high net-baryon densities and relatively low temperature sin heavy ion collisions at the Facility of Antiproton and Ion Research (FAIR) in Darmstadt. It is expected that the QCD phase diagram exhibits a rich structure, such as a first- order phase transition between hadronic and partonic matter which terminates in a critical point, or exotic phases like quarkyonic matter. The discovery of these landmarks would be a breakthrough in our understanding of the strong interaction and is therefore in the focus of various high-energy heavy-ion research programs. The Compressed Baryonic Matter (CBM) experiment at FAIR will play a unique role in the exploration of the QCD phase diagram in the region of high net-baryon densities, because it is designed to run at unprecedented interaction rates. High-rate operation is the key prerequisite for high-precision measurements of multi-differential observables and of rare di- agnostic probes which are sensitive to the dense phase of the nuclear fireball.

We are focusing on the results of JINR participation in the CBM experiment. JINR teams are responsible on the design, the coordination of superconducting(SC) magnet manufacture, its testing and installation in CBM cave. Together with Silicon Tracker System it will provide the momentum resolution better 1% for different configuration of CBM setup. The characteristics and technical aspects of the magnet are discussed. JINR plays also a significant role in the manufacture of two straw tracker station for the muon detection system. JINR team takes part in the development of new method for simulation, processing and analysis experimental data for different basic detectors of CBM.

# QCD AND HADRONIC FINAL STATE MEASUREMENTS AT HERA

B.B. Levchenko<sup>†</sup>,  
(On behalf of the H1 and ZEUS Collaborations)

(1) *D. V. Skobeltsyn Institute of Nuclear Physics, M. V. Lomonosov Moscow State University,  
Moscow, Russia*

*† E-mail: levchen@mail.desy.de*

Highlights from two HERA experiments, H1 and ZEUS, on the measurements of jet cross sections and the hadronic final state in electroweak  $e \pm p$  collisions are reviewed. The data were taken since 1992 till 2007, at proton beam energies of 920, 820, 575 and 460 GeV and an electron beam energy of 27.5 GeV. These are measurements of inclusive multijet production as well as the production of mesons with charm and beauty quarks in photoproduction and deep-inelastic scattering. Perturbative next-to-leading-order QCD predictions are compared to the measurements.



# SEARCH FOR THE SIGNS OF INTRINSIC ALPHA-CLUSTERING IN MULTIPARTICLE PROCESSES INDUCED BY COLLISIONS OF LIGHT NUCLEI

A.Kh. Arginova, A.Sh. Gaitinov, A.A. Loctionov  
Institute of Physics and Technology, Almaty, Kazakhstan  
[loction@sci.kz](mailto:loction@sci.kz)

## 1. Introduction

Understanding of the initial stages of high energy nuclear interactions is one of the key problems for heavy ion physics. Importance of the new insight on the problem has been pointed out in the discussions [1, 2] just after QM 2014. The broad system size studies are being performed in the modern NA 61/SHINE experiments at SPS as a part of the program of a systematic search for the onset of deconfinement [3, 4]. The better understanding of the initial state characteristic can be obtained from small system interactions. These problems have been considered at QM 2014 [5], and at WWND 2016 [6] and more detailed at QM 2015 [7]. The new perspective researches in the fixed target experiment BM@N, as the 1-st stage in the heavy ion program at NICA project [8], will be launched in next year. In the report the system size dependence for the multiparticle processes has been investigated in the centrality selected collisions of light-light - (C, O, Ne)+(C/N/O), intermediate-light - (Si, S)+(C/N/O) and heavy-heavy - (Au, Pb)+(Ag/Br) nuclei on the data of JINR-AGS-SPS fixed target emulsion experiments. The previous considerations have shown that there is a clear trend to the fluctuation enhancement with system size decreasing [9]. The strong fluctuations in initial conditions for interactions of light nuclei have been interpreted as the sign of intrinsic alpha-clustering [10].

## 2. Multiplicity distributions for “central” nuclear interactions

For the more realistic solution of the centrality determination problem, the new measurable estimator of centrality has been proposed and realized [11], using correlations between sum of all fast charged, – light and heavy, - fragment-spectators  $A_f$ : proton-spectators, alpha-particle-spectators and heavy mass fragment-spectators and multiplicity. In this approach the number of participant nucleons for projectile  $A_{\max}$  nucleus  $N_{\text{part}}(\text{projectile}) = A_{\max} - A_f$ . The model of quantitative Glauber nuclear geometry for description of (near) right spherical nucleus collisions was not used [9]. It should be stressed that centrality problems are very important for heavy ion physics. Great significance of heavy fragment analysis has already been pointed out in the works of NA-49 [10]. The interesting concept of centrality determination, using collider as a mass-spectrometer, was proposed and modelled [11]. Accuracy of the projectile spectator detector is significantly enhanced in new NA61/SHINE experiments [12]. The broad-ranging investigations were performed in the NICA project [13]. The centrality problems in connection with multiparticle production recently were considered [14].

In order to study the multiplicity distributions in the “genuine production processes” we have to remove or, in the least, minimize the uncontrolled fluctuations of volume of interaction. The projectile participants are adequately determined with our centrality estimator. In order to get rid of fluctuations in the target we have to consider the most central nuclear interactions [17]. In line with this perspective we compare the multiplicity distributions for “most central” interactions in light-light, intermediate-light and heavy-heavy collisions. The results have shown that the width of the multiplicity distributions is inversely proportional to the volume of interacting systems [15]. It is very significant trend with the connection of the system size behavior for different measures of fluctuations [18]. On the other hand it can provide a new insight into cluster geometry for collision of light nuclei [15]. It should be pointed out in this

context that the interesting patterns reflecting the alpha-cluster nature of the exited fireballs recently have been computed for asymmetrical interactions of light-heavy nuclei [19].

### 3. Pseudorapidity spectra for “central” nuclear interactions

The pseudorapidity spectra, as and multiplicity distributions, are the important characteristics of the production processes. In this section e-by-e analysis of the pseudorapidity shape, - deviation from Gaussian, - have been performed. The fourth statistical moment, - Kurtosis (K), tell us how tall and sharp the central peak is relatively to Gaussian. The third statistical moment, - Skewness (S) in this context “works” as an indicator of analysis accuracy. The analyses of central heavy ion collisions (Au, Pb)+(Ag/Br) at BNL and SPS energies with high multiplicities have clear demonstrated the well-known plateau at midrapidity:  $K(\text{Pb}(\text{SPS})+\text{Ag}/\text{Br}) = -0.73 \pm 0.09$ ,  $K(\text{Au}(\text{BNL})+\text{Ag}/\text{Br}) = -0.69 \pm 0.15$ , with high accuracy:  $S(\text{Pb}(\text{SPS})+\text{Ag}/\text{Br}) = 0.04 \pm 0.05$ ,  $S(\text{Au}(\text{BNL})+\text{Ag}/\text{Br}) = 0.03 \pm 0.11$ .

For intermediate-light - (Si, S)+(C/N/O) collisions at JINR, AGS, SPS energies the Kurtosis analyses give us the “baseline structure” for the understanding of multiplicity dependence.

For the group of central light-light - (C, O, Ne)+(C/N/O) interactions at JINR energies with relatively low multiplicities the Kurtosis analysis has shown the diffuse pattern of plateau at midrapidity:  $K(\text{C, O, Ne}(\text{JINR})+(\text{C}/\text{N}/\text{O})) = -0.82 \pm 0.53$ . The accuracy is  $S(\text{C, O, Ne}(\text{JINR})+(\text{C}/\text{N}/\text{O})) = -0.003 \pm 0.42$ . The new experiments with high resolution and statistics are needed in order to make the reliable inference on the precision description of the pseudorapidity spectra in the central light-light interactions at JINR energies.

### 4. The NICA study of intrinsic alpha-clustering in multiparticle processes

The planned experiments at NICA [8] can be very useful for search for the signs of intrinsic alpha-clustering in multiparticle processes. These tasks can be performed with high resolution and statistics both on the 1-st stage in the fixed target experiment BM@N, focused on production of strange matter in nuclear collisions at “old JINR” beam energies, and in the collider MPD program at new interval of JINR energies.

### 5. Summary

The analyses of the centrality selected collisions of light-light, intermediate-light and heavy-heavy nuclei have revealed the essential difference in multiparticle processes for light-light interactions. The intrinsic alpha-clustering in light nuclei could be a reliable source of such difference.

### Reference

1. F. Antinori et al., 24-26 May 2014, arXiv: 1409.2981.
2. U. Heinz et al., 13-15 Sep 2014, arXiv: 1501.06477.
3. M. Mackowiak-Pavlovska, Nucl. Phys. A 00(2016) 1-5.
4. E. Andronov, “CPOD 2016”, Wroclaw, Poland, 2016.
5. B. Schenke, R. Venugopalan, Nucl. Phys A 931 (2014) c1039-c1044.
6. Q. Xu, 32-nd WWND 2016, Guadeloupe, 28 Feb-5Mar 2016.
7. P. Stankus, XXV QM 2015, Kobe, Sep 27-Oct 3, 2015.
8. В. Кекелидзе, Сессия ОФН РАН, Дубна, 11 апреля 2016.
9. A.Kh. Argynova, A.Sh. Gaitinov, A.A. Loctionov, <http://indico.cern.ch/event/219436/session/2/>, XXIV QM2014, 2014.
10. M. Appelschauser et al., (NA 49 Collaboration), Eur. Phys. J. – A2. – (1998). – 383 p.
11. Tarafdar, Z. Citron, A. Milov, A Centrality Detector Concept, ArXiv:1405.4555, 2014, QM2014, Darmstadt.
12. N. Abgrall et al., NA61/SHINE facility at CERN SPS, arXiv: 1401.4699, 19 Jan 2014.
13. MPD Forward Hadron Calorimeter (FHCAL), LHEP JINR, Dubna, pp.62, Mar. 21, 2016
14. T. Drozhzheva, G. Feofilov, et al., LXV Intern. Conf. “Nucleus 2015”, S-Petersburg, June 29-July 3, 2015.
15. A.Kh. Argynova, A.Sh. Gaitinov, A.A. Loctionov, SQM 2015, Poster, JINR, 2015.
16. A.Kh. Argynova, A.Sh. Gaitinov, A.A. Loctionov, Intern. Conf. ICNRP'13, 2013, Almaty, pp. 194-200.
17. E. Bratkovskaya, HIC for FAIR, WS, Frankfurt, 2015.
18. V.V.Begun, M. Gazdzicki et al., arXiv: 0404056, 2004.
19. W. Broniowski et al., Phys. Rev. Lett., 112, 112501, (2014); J. of Phys. Conf. series, 630(2015) 012060.



# THE COMPARATIVE ANALYSIS OF ELASTIC PION-NUCLEUS SCATTERING WITHIN THE MICROSCOPIC FOLDING AND LOCAL KISSLINGER-ERICSON OPTICAL POTENTIALS

V.K. Lukyanov<sup>1†</sup>, E.V. Zemlyanaya<sup>1</sup>, K.V. Lukyanov<sup>1</sup>, I.A.M. Abdul-Magead<sup>2</sup>,

(1) *Joint Institute for Nuclear Research, Dubna, Russia*

(2) *Cairo University, Giza, Cairo, Egypt*

† *E-mail: vlukyanov@jinr.ru*

Elastic scattering cross sections were calculated and compared to the data of  $\pi^\pm + {}^{28}\text{Si}$ ,  ${}^{58}\text{Ni}$ ,  ${}^{40}\text{Ca}$ ,  ${}^{208}\text{Pb}$  at energies 160, 180, 230, 290 MeV by using the both microscopic optical potentials (OP), the high-energy folding OP [1] adapted in [2, 3] for pion scattering and the local version [4] of Kisslinger potential [5]. In the folding OP one uses the nuclear density distribution functions while parameters of the elementary  $\pi\text{N}$ -scattering amplitude were fitted to the data. Difference of them from those for the pion scattering on free nucleons let to estimate the so-called in-medium effect on pions scattered on bounded nucleons. As to the modified Kisslinger OP its fitted parameters were taken from [6]. The cross sections were obtained by solving the relativistic wave equation transformed to its non-relativistic form and then computed using the DWUCK4 code [7]. Doing so the relativistic and distortion effects on the process were accounted for exactly. In calculations, a fairly well agreement with experimental data was obtained and the decisive role of a surface region of potentials was established where both OPs occur in close coincidence.

## References

- [1] V.K. Lukyanov, E.V. Zemlyanaya, K.V. Lukyanov, *Physics of Atomic Nuclei*. **69**, 240 (2006); JINR Preprint P4-2004-115, Dubna (2004).
- [2] V.K. Lukyanov, E.V. Zemlyanaya, K.V. Lukyanov, Ali El Lithy, Ibrahim Abdulmagead, B. Slowinski, *Bull. Russ. Acad. Sciences, Physics*, **77**. No.4, 427 (2013).
- [3] V.K. Lukyanov, E.V. Zemlyanaya, K.V. Lukyanov, A. Ellithy, I.M. Abdul-Magead, *Int. J. Mod. Phys. E* **24**, No.5, 1550035 (2015).
- [4] M. Krell, T.E.O. Ericson, *Nucl. Phys.* **B 11**, 521 (1969).
- [5] L.S. Kisslinger, *Phys. Rev.* **98**, 761 (1955).
- [6] M.B. Johnson, G.R. Satchler, *Ann. Phys.* **A 248**, 134 (1996).
- [7] P.D. Kunz, E. Rost, in *Computational Nuclear Physics*, ed. by K. Langanke, et.al., Eds., New York: Springer Verlaq, **2**, 88 ('993).

# PDF OF HEAVY QUARKS AND GLUONS IN PROTON AND HARD PROCESSES AT LHC ENERGIES

G.I. Lykasov<sup>1,†</sup>, A.V. Lipatov<sup>1,2</sup>

<sup>1</sup>*JINR, Dubna, 141980, Moscow region*

<sup>2</sup>*Skobeltsyn Institute of Nuclear Physics, Moscow State University, 119991 Moscow, Russia*

† *E-mail: lykasov@jinr.ru*

The talk consists of two parts: 1) short overview on the hypothesis of the valence-like heavy quark (*intrinsic*) components in a nucleon and their possible search for in hard processes at LHC; 2) a new modification of the unintegrated gluon distributions at low  $x$  and their application to the analysis of hard processes at LHC energies and mid rapidities.

1)

Firstly, a short overview on the Fock quark states, so called *intrinsic* quark distributions in a nucleon is presented. Up to now this hypothesis has not yet been confirmed or rejected. Therefore, we focus on the observable very sensitive to the non-zero *intrinsic* charm (IC) contribution to the proton density. It is the ratio between the differential cross sections of the photon or  $Z$ -boson and  $c$ -jet production in the  $pp$  collision,  $\gamma(Z) + c$ , and the  $\gamma(Z)$  and the  $b$ -jet production. It is shown that this ratio can be approximately flat or increasing at large  $\gamma(Z)$  transverse momenta  $p_T$  and their pseudo-rapidities  $1.5 < \eta < 2.4$  if the IC contribution is taken into account. On the contrary, in the absence of the IC this ratio decreases as  $p_T$  grows. We also present the ratios of the cross sections integrated over  $p_T$  as a function of the IC probability  $w$ . It is shown that these ratios are mostly independent on the theoretical uncertainties, and such predictions could therefore be much more promising for the search for the *intrinsic* charm signal at the LHC compared to the predictions for  $p_T$ -spectra, which significantly depend on these uncertainties.

2)

Secondly, we study the role of the non-perturbative input to the transverse momentum dependent (TMD) gluon density in hard processes at the LHC. We derive the input TMD gluon distribution at a low scale  $\mu_0^2 \sim 1 \text{ GeV}^2$  within the Regge theory and the parameters find from a fit of inclusive hadron spectra measured at low transverse momenta in  $pp$  collisions at the LHC and demonstrate that the best description of these spectra for larger hadron transverse momenta can be achieved by matching the derived TMD gluon distribution with the exact solution of the Balitsky-Fadin-Kuraev-Lipatov (BFKL) equation obtained at low  $x$  and small gluon transverse momenta outside the saturation region. Then, we extend the input TMD gluon density to higher  $\mu^2$  numerically using the Catani-Ciafaloni-Fiorani-Marchesini (CCFM) gluon evolution equation. Special attention is paid to phenomenological applications of the obtained TMD gluon density to some LHC processes, which are sensitive to the gluon content of a proton.

**SPIN CORRELATIONS OF THE FINAL LEPTONS IN THE  
TWO-PHOTON PROCESSES  $\gamma\gamma \rightarrow e^+e^-, \mu^+\mu^-, \tau^+\tau^-$**

Valery V. Lyuboshitz<sup>†</sup>

in collaboration with Vladimir L. Lyuboshitz

*Joint Institute for Nuclear Research,  
141980 Dubna, Moscow Region, Russia  
<sup>†</sup> E-mail: Valery.Lyuboshitz@jinr.ru*

The theoretical study of spin structure for the process of electron-positron pair production by two photons  $\gamma\gamma \rightarrow e^+e^-$  is performed. It is demonstrated that, if the primary photons are unpolarized, the final electron and positron remain unpolarized as well but their spins prove to be strongly correlated. Explicit expressions for the components of the correlation tensor of the final ( $e^+e^-$ ) system are derived, and the relative fractions of singlet and triplet states of the ( $e^+e^-$ ) pair are found. It is established that in the process  $\gamma\gamma \rightarrow e^+e^-$  one of the incoherence inequalities of the Bell type for the correlation tensor components is always violated and, thus, spin correlations of the electron and positron in this process have the strongly pronounced quantum character.

Analogous consideration can be wholly applied as well to the two-photon processes  $\gamma\gamma \rightarrow \mu^+\mu^-$  and  $\gamma\gamma \rightarrow \tau^+\tau^-$ , which become possible at considerably higher energies.

# RENORMDYNAMICS AND PRODUCTION OF FRACTALS, FLUCTONS, SOLITONS, STRINGS, UNPARTICLES ...

Nugzar Makhaldiani

*JINR*

*mnv@jinr.ru*

Concise introduction in renormdynamics with solvable models of (non)perturbative QCD and exotic states of fractals, fluctons, solitons, strings, unparticles...

## References

- [1] Nugzar Makhaldiani, Renormdynamics and Hadronization, Journal of Physics: Conference Series **668** 012114 (2016) doi:10.1088/1742-6596/668/1/012114
- [2] Nugzar Makhaldiani, Renormdynamics, Discrete Dynamics and Spin, Journal of Physics: Conference Series **678** 012029 (2016) doi:10.1088/1742-6596/678/1/012029

# RATIOS OF HELICITY AMPLITUDES FOR EXCLUSIVE $\rho^0$ ELECTROPRODUCTION ON TRANSVERSELY POLARIZED PROTON

S.I. Manaenkov<sup>1†</sup>

(1) *National Research Centre "Kurchatov Institute" Petersburg Nuclear Physics Institute, on behalf of the HERMES Collaboration*

<sup>†</sup> *E-mail: manaenkov\_si@pnpi.nrcki.ru*

Exclusive  $\rho^0$ -meson electroproduction is studied in the HERMES experiment, using the 27.6 GeV longitudinally polarized electron/positron beam of HERA and a transversely polarized hydrogen target in the kinematic region  $1.0 \text{ GeV}^2 < Q^2 < 7.0 \text{ GeV}^2$ ,  $3.0 \text{ GeV} < W < 6.3 \text{ GeV}$ , and  $-t' < 0.4 \text{ GeV}^2$ . Using an unbinned maximum likelihood method, 25 real functions are extracted, which are the real and imaginary parts of the ratios of the helicity amplitudes for the  $\rho^0$ -meson production by the virtual photon. All the amplitudes are divided by the dominant amplitude  $T_{0\frac{1}{2}0\frac{1}{2}}$ , which is the nucleon-helicity-non-flip amplitude describing the production of the longitudinal  $\rho^0$  meson by the longitudinal virtual photon. The usage of the transversely polarized target allows for the first time the extraction of the ratios of certain nucleon-helicity-flip amplitudes to  $T_{0\frac{1}{2}0\frac{1}{2}}$ . The ratios of nucleon-helicity-non-flip amplitudes are found to be in good agreement with those from the previous HERMES analysis.

## **A NEW PLATFORM FOR RESEARCH AND APPLICATIONS WITH ELECTRONS AT ORSAY: PRAE**

Dominique Marchand  
On behalf of the PRAE collaboration

*Institut de Physique Nucléaire d'Orsay, CNRS/IN2P3 and Université Paris-Sud, UMR 8608,  
Université Paris-Saclay, 91406 Orsay, France  
E-mail: marchand@ipno.in2p3.fr*

The PRAE platform which will be built in the Orsay campus is based on a high quality pulsed electron beam of energy between 30 to 140 MeV. The beam will be delivered to one of the three beam lines, each of them being designed to fulfill specific research and applications projects. The highest energy electron beam will be used to perform pre-clinical studies in radiotherapy. A second beam line will be fully instrumented to test and optimize detectors whereas the third one will be dedicated to nuclear physics experiments.

After an overview of the new facility and its main goals regarding the different topics that can be addressed, we will focus on the experiment we propose to measure the electric form factor of the proton in the  $Q^2$  range of  $10^{-4}$  -  $10^{-5}$  (GeV/c)<sup>2</sup> increasing the number of data to be used to extract the proton charge radius.

*This work has been partly funded by the P2IO LabEx (ANR-10-LABX-0038) in the framework « Investissements d'Avenir » (ANR-11-IDEX-0003-01) managed by the French National Research Agency (ANR).*



## SEARCH FOR ANNUAL AND DAILY VARIATIONS OF FE-55 NUCLEUS WEAK DECAY PARAMETERS

S.N. Mayburov

*Lebedev Institute of Physics RAS*

Search of temporal variations of nucleus decay parameters are important, because their observation can be the signal of unknown physical effects. Earlier, several experiments reported the annual decay rate oscillations in alpha and beta-decays of some heavy nuclides of the order .05 %. In our experiment decay rate variations in inverse beta-decay (electron capture) of Fe-55 isotope. In this process K-shell electron absorbed by nuclei and electron neutrino emitted. It accompanied by X-ray with energy 5,9 or 6,4 KeV which in our set-up is detected by cooled Si-Pin detectors. Together with observed Fe-55 decay exponent with lifetime 1004 days, annual oscillation component value is found to be equal to be (.2 +/- .04)%. Annual maximal rate phase is equal to .09 +/- .02 and corresponds to February 2 in agreement with published alpha-\beta- decay results. The similar measurements in orbital flight conditions are planned for 2018 at International Space Station as part of DODO project.

# INITIAL STATE FLUCTUATIONS IN HEAVY-ION COLLISIONS FROM SPS TO LHC

J. Milosevic<sup>1†</sup>

(1) *Vinca Institute of Nuclear Sciences*

† *E-mail: Jovan.Milosevic@cern.ch*

Fluctuations in the positions of the nucleons from the colliding nuclei cause appearance of the Fourier harmonics of the order higher than 2. Most pronounced harmonic between them corresponds to triangular flow. It is measured at different colliding energies from the SPS till the top LHC energy. These fluctuations are responsible also for appearance of the higher order harmonics in ultra-central symmetric and in highly asymmetric collisions. The initial-state energy density is not a smooth, but has a lumpy structure. Local hotspots perturb the event plane (EP) of a smooth medium such that the EP is not a global quantity anymore but depends on both,  $p_T$  and  $\eta$ . This cause breaking of two-particle Fourier harmonic factorization into a product of single-particle anisotropies. This effect, which happens on partonic level, appears through newly introduced sub-leading flows which are measured by the CMS.

# HEAVY-HEAVY AND HEAVY-LIGHT QUARKS INTERACTIONS FROM INSTANTON VACUUM

M. Musakhanov<sup>1†</sup>

(1) *National University of Uzbekistan*

† *E-mail: musakhanov@gmail.com*

The QCD vacuum is populated by instantons that correspond to the tunneling processes in the vacuum. This mechanism creates the strong vacuum gluon fields. As result, The QCD vacuum instantons induce very strong interactions between light quarks, which was initial almost masses. Such strong interactions bring about a large dynamical mass  $M$  of the light quarks and can bound them to produce almost massless pions in accordance with the spontaneous breaking of chiral symmetry (SSB). On the other hand, the QCD vacuum instantons also interact with heavy quarks and responsible for the generation of the heavy-heavy and heavy-light quarks interactions, which has a traces of the SSB (see [1] and references therein). If we take the average instanton size  $=0.35$  fm, and the average inter-instanton distance  $R=0.856$  fm from our previous estimates, we obtain at leading order in the  $1/N_c$  expansion the dynamical light quark mass to be  $M=570$  MeV and the instanton media contribution to the heavy quark mass  $M=148$  MeV. These factors define the coupling between heavy-heavy and heavy-light quarks induced by the QCD vacuum instantons.

We consider first the instanton effects on the heavy-quark potential, including its spin-dependent part. We also discuss those effects on the masses of the charmonia and their hyperfine mass splittings [1].

At the second part of the present talk, we discuss the interactions between a heavy quark and light mesons in the case of the light quark flavor number  $N_f=2$  case [2].

[1] U. Yakhshiev, Hyun-Chul Kim, B. Turimov, M.M. Musakhanov, Emiko Hiyama, Instanton effects on the heavy-quark static potential, [arXiv:1602.06074 [hep-ph]].

[2] M. Musakhanov, Heavy-light quarks interactions in QCD vacuum, PoS Baldin-ISHEPPXXII (2015) 012 [arXiv:1412.4472 [hep-ph]].

## References

- [1] U. Yakhshiev, Hyun-Chul Kim, B. Turimov, M. Musakhanov, Emiko Hiyama, Instanton effects on the heavy-quark static potential, [arXiv:1602.06074 [hep-ph]]
- [2] M. Musakhanov, Heavy-light quarks interactions in QCD vacuum, PoS Baldin-ISHEPPXXII (2015) 012 [arXiv:1412.4472 [hep-ph]]

# THE ROLE OF INITIAL STATE IN HEAVY ION COLLISIONS. "HORN"-EFFECT

G. Musulmanbekov<sup>†</sup>

*JINR, Dubna*

<sup>†</sup> *E-mail: genis@jinr.ru*

A new mechanism is proposed for interpretation of the non-monotonic, enhanced yield of hyperons and positive strange mesons (also known as "horn" effect) that was observed in central heavy ion collisions in the experiment NA49 at SPS and later confirmed by Beam Energy Scan (BES) program of STAR collaboration at RHIC. We argue that the data indicate the transition of the nucleons in the overlap region of colliding nuclei with high nuclear density into a certain hyperon phase. This nucleon-to-hyperon transition is accompanied by enhanced yields of positive and neutral kaons. The "horn"-effect is a consequence of an interplay between the energy/baryon density attained in the overlap region of colliding nuclei and the overlap time. According to the proposed mechanism the same effect should be observed for the yield of neutral kaons as well.

In semi-central heavy ion collisions a strong magnetic field and very large orbital angular momentum can be created. Possible "global" polarization of hyperons (created by above nucleon-to-hyperon transition mechanism) induced by these phenomena is discussed.

# FEMTOSCOPIC MEASUREMENTS OF KAONS IN THE SELEX EXPERIMENT

G.A. Nigmatkulov<sup>1†</sup>

(1) *National Research Nuclear University MEPHI (Moscow Engineering Physics Institute)*

† *E-mail: ganigmatkulov@mephi.ru*

We report on the measurement of Bose-Einstein correlations of pions and kaons produced in  $600 \text{ GeV}/c \Sigma^-A$ ,  $\pi^-A$  and  $540 \text{ GeV}/c pA$  interactions in the SELEX experiment. These correlations allow to study spatial and temporal properties of the particle emitting source using two-particle correlation function. The charged meson correlation functions are constructed for several pair transverse momentum ranges for each incident beam type. The extracted one-dimensional pion and kaon emitting source radii slightly decrease with increasing the pair transverse momentum. In addition, the material dependence of the source radii is measured.

**EMISSION OF d, t,  $^3\text{He}$  AND  $\alpha$ -PARTICLES FROM  
 $^{12}\text{C}$  NUCLEI EXCITED BY INTERMEDIATE ENERGY PHOTONS**

A.A.Turinge, A.M.Lapik, A.N.Mushkarenkov, V.G.Nedorezov  
for the GRAAL collaboration

*Institute for Nuclear Research RAS, Moscow*

New GRAAL data on the fragmentation of carbon nuclei by photons at 800 - 1500 MeV are discussed. In addition to previously published results for the proton and neutron emission probabilities at different multiplicity, there are presented preliminary results on the yields of heavier fragments as d, t,  $^3\text{He}$  and  $\alpha$ -particles. Obtained results are compared with theory predictions and another fragmentation experimental data measured in different reactions induced by photons, electrons and relativistic ions.

# ELECTROPRODUCTION OF LIGHTEST NUCLEON RESONANCES UP TO $Q^2=12 \text{ GeV}^2$ IN QUARK MODELS AT LIGHT FRONT

I.T. Obukhovskiy<sup>1†</sup>, A. Faessler<sup>2</sup>, T. Gutsche<sup>2</sup> and V.E. Lyubovitskij<sup>2,3,4</sup>

- (1) *Institute of Nuclear Physics, Moscow State University, 119991 Moscow, Russia*
  - (2) *Institute for Theoretical Physics, University of Tuebingen, Auf der Morgenstelle 14, D-72076 Tuebingen, Germany*
  - (3) *Department of Physics, Tomsk State University, 634050 Tomsk, Russia*
  - (4) *Laboratory of Particle Physics, Mathematical Physics Department, Tomsk Politechnic University, Lenin Avenue 30, 634050 Tomsk, Russia*
- † *E-mail: obukh@nucl-th.sinp.msu.ru*

Last decade has been marked by significant progress in the experimental study of low-lying baryonic resonances (the radial/orbital nucleon excitations with  $J^P = \frac{1}{2}^\pm, \frac{3}{2}^\pm, \frac{5}{2}^\pm$ ). Specifically new insights have been obtained in  $\pi$  and  $2\pi$  electroproduction on the proton with the polarized electron beam at JLab (CLAS Collaboration). In the context of projected extensive studies of the baryon electroproduction up to  $Q^2 = 12 \text{ GeV}^2$ , there is an interest in calculation of electrocouplings of baryons at large  $Q^2$ . Rough estimates can be made on the basis of light-front quark models which are founded on a consistent relativistic theory for composite systems with a fixed number of constituents. Such approach implies the construction of a good basis of quark light-front configurations possessing the definite value of the total angular momentum  $J$  and satisfying the Pauli exclusion principle. Our approach is to fit parameters of light-front quark configurations to the elastic nucleon form factors extracted from recent data on polarized electron scattering and use these to calculate the transition form factors at large  $Q^2$  up to  $12 \text{ GeV}^2$ .

In Ref. [1] we have generalized our late results [2] on the Roper resonance electroproduction at  $Q^2 < 4 \text{ GeV}^2$  by going to more high  $Q^2$ . It has taken to rewrite our old non-relativistic model in terms of quark configurations at the light front. The decisive advantage of the light-front approach is the separation of the total momentum of the system from the inner (relative) moments of quarks  $\lambda^\mu = (x_2 p_1^\mu - x_1 p_2^\mu)/(x_1 + x_2)$ ,  $\Lambda^\mu = (x_1 + x_2)p_3^\mu - x_3(p_1^\mu + p_2^\mu)$ , where  $\lambda_\perp$ ,  $\Lambda_\perp$  and  $x_i$  are invariants of Lorentz transformations. Starting from the relative moments  $\lambda^\mu$ ,  $\Lambda^\mu$  one can define the inner (orbital) angular momentum  $L$  in the rest frame of the  $3q$  system (or in the rest frame of a two-quark subsystem), and add up the orbital momentum  $L$  and the quark spin  $S$  using the relativistic technique developed long ago [3, 4] to define the total angular momentum  $\mathbf{J} = \mathbf{L} + \mathbf{S}$ . However, it should be noted that the Melosh transformation from the canonical spin to the light-front spin generates relativistic spin wave functions with only approximately correct  $\mathbf{J}^2$  because of the interaction dependence of the light-front rotation generators  $\mathbf{J}_\perp$ .

At the light front the electrocouplings sought are given by matrix elements of the “plus” component of quark current  $I_q^+ = I_q^0 + I_q^3$  for transitions  $N_{1/2^+} \rightarrow N_{J^-}$ ,  $R_{1/2^+}$  in the Breit frame (i.e. for  $q^\nu = P'^\nu - P^\nu = \{0, \mathbf{q}_\perp, 0\}$ ) between front states. In Ref. [1] we have shown that the given LF quark model allows for a good description of all the new data on nucleon form factors in a large interval of  $Q^2$  from 0 up to  $35 \text{ GeV}^2$ . The model has only 5 free parameters (including a small anomalous magnetic moment of the quark), which are fitted to the data. In the case of the Roper resonance the main problem is that

its inner structure cannot be adequately described in terms of only constituent quark degrees of freedom, and thus other (more soft) degrees of freedom should be taken into consideration along with the quark core. It is evident that at high  $Q^2$  the contribution of such soft components to the transition form factors is quickly dying out with rising of the momentum transfer, and only the contribution of the quark core survives. We considered the Roper resonance  $R = N_{1/2^+}(1440)$  as a mixed state of the radially excited quark configuration  $(3q)^*$  and the “hadron molecule” (a loosely bound state of nucleon and  $\sigma$  meson). The dynamic of  $N\sigma$  component is considered in the framework of the hadronic molecular approach (e.g., see Ref. [5] and references therein) which is manifestly Lorentz invariant. The two-component model allows to describe with reasonable accuracy the recent CLAS electroproduction data (Figure 1) at low and moderate  $Q^2$  and predict the behavior of helicity amplitudes at more high  $Q^2$  up to 12  $\text{GeV}^2$ .

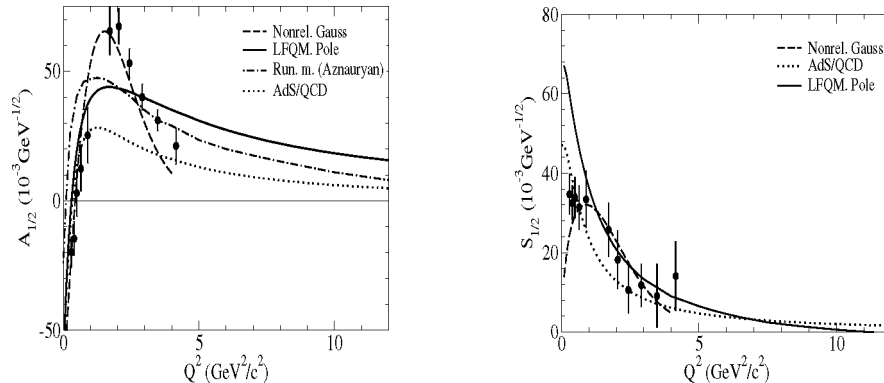

Figure 1: Transverse helicity amplitude  $A_{1/2}$  (left panel) and longitudinal amplitude  $S_{1/2}$  (right panel) of the Roper resonance electroproduction in different approaches. Solid line: the two-component model  $N^* = \cos\theta(3q)^* + \sin\theta N\sigma$ ,  $\cos\theta = 0.57$ , with a pole wave function for the  $(3q)^*$  component[1]. Dashed line: the same model, but with the nonrelativistic Gaussian wave function[2]. Pointed line: results from the AdS/QCD approach[6]. Dash-pointed line: the comparison with results of the model with running quark mass[7].

## References

- [1] I.T. Obukhovskiy *et al.*, Phys. Rev. D **89**, 014032 (2014).
- [2] I.T. Obukhovskiy *et al.*, Phys. Rev. D **84**, 014004 (2011).
- [3] Shirokov Iu. M., Soviet Physics JETP **8**, 703 (1959).
- [4] L.A. Kondratyuk and M.V. Terent’ev, Preprint ITEP-48 (1979) (in Russian).
- [5] A. Faessler, T. Gutsche, V.E. Lyubovitskij, and Y.L. Ma, Phys. Rev. D **76**, 014005 (2007).
- [6] T. Gutsche, V.E. Lyubovitskij *et al.*, Phys. Rev. D **87**, 016017 (2013).
- [7] I.G. Aznauryan and V.D. Burkert, *et al.*, Phys. Rev. C **85**, 055202 (2012).



# PROBING THE X(3872) MESON STRUCTURE WITH NEAR-THRESHOLD PP AND PA COLLISIONS AT NICA

M.Yu. Barabanov<sup>1</sup>, S.-K. Choi<sup>2</sup>, S.L. Olsen<sup>3†</sup>, A.S. Vodopyanov<sup>1</sup> and A.I. Zinchenko<sup>1</sup>

(1) *Joint Institute for Nuclear Research, Joliot-Curie 6 Dubna Moscow region Russia 141980*

(2) *Department of Physics, Gyeongsang National University, Jinju 660-701, Korea*

(3) *Center for Underground Physics, Institute for Basic Science, Daejeon 34074, Korea*

† *E-mail: solsensnu@gmail.com*

The spectroscopy of charmonium-like mesons with masses above the  $2m_D$  open charmed threshold has been full of surprises and remains poorly understood [1]. The currently most compelling theoretical descriptions of the mysterious  $XYZ$  mesons attributes them to hybrid structure with a tightly bound  $c\bar{c}$  diquark [2] or a  $c\bar{c}q\bar{q}'$  tetraquark [3] core that strongly couples to  $S$ -wave  $D^{(*)}\bar{D}^{(*)}$  molecule-like structures. In this picture, the production of an  $XYZ$  particle in high energy hadron collisions and its decays to light hadron + charmonium final states proceed via the core component of the meson, while decays to pairs of open-charmed mesons proceed via the  $D^{(*)}\bar{D}^{(*)}$  component.

These ideas have been applied with some success to the  $X(3872)$  [2], where a detailed calculation finds a  $c\bar{c}$  core component that is only about 5 percent of the time, with the  $D\bar{D}^*$  component (mostly  $D^0\bar{D}^{*0}$ ) accounting for the rest. In this picture, illustrated in cartoon form in Fig. 1, the  $X(3872)$  is composed of three rather disparate components: a small charmonium-like  $c\bar{c}$  core with  $r_{\text{rms}} < 1$  fm, a larger  $D^+D^{*-}$  component with  $r_{\text{rms}} = \hbar/\sqrt{2\mu_+B_+} \simeq 1.5$  fm and a dominant  $D^0\bar{D}^{*0}$  component with a huge,  $r_{\text{rms}} = \hbar/\sqrt{2\mu_0B_0} > 9$  fm spatial extent. Here  $\mu_+$  ( $\mu_0$ ) and  $B_+$  ( $B_0$ ) denote the reduced mass for the  $D^+D^{*-}$  ( $D^0\bar{D}^{*0}$ ) system and the relevant *binding energy*:  $|(m_D + m_{D^*}) - M_{X(3872)}|$  ( $B_+ = 8.2$  MeV and  $B_0 < 0.3$  MeV). The different amplitudes and spatial distributions of the  $D^+D^{*-}$  and  $D^0\bar{D}^{*0}$  components ensure that the  $X(3872)$  is not an isospin eigenstate; instead it is mostly  $I = 0$ , but has a significant ( $\sim 25$  percent)  $I = 1$  component.

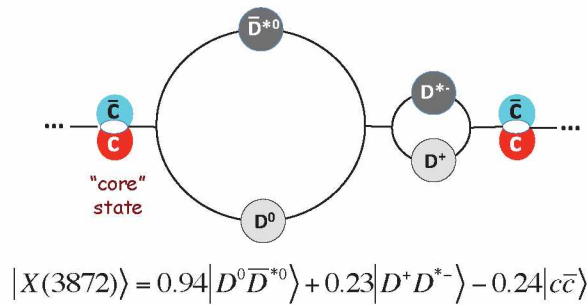

Figure 1: The  $X(3872)$  in a hybrid picture. The numerical values come from ref. [2].

In the hybrid scheme, an  $X(3872)$  is produced in high-energy  $pN$  collisions via its compact ( $r_{\text{rms}} < 1$  fm) charmonium-like structure and this rapidly mixes (in a time  $t \sim \hbar/\delta M$ ) into huge and fragile, mostly  $D^0\bar{D}^{*0}$ , molecule-like structure;  $\delta M$  is the difference between the  $X(3872)$  mass and that of the nearest  $c\bar{c}$  mass pole core state, which we take to be that of the the  $\chi_{c1}(2P)$  pure charmonium state that is expected to lie

about  $20 \sim 30$  MeV above  $M_{X(3872)}$  [4]. In this case, the mixing time,  $c\tau_{\text{mix}} = 5 \sim 10$  fm, is much shorter than the the lifetime of the  $X(3872)$ , which is  $c\tau_{X(3872)} > 150$  fm [5].

The NICA superconducting collider is uniquely well suited to test this picture for the  $X(3872)$  (and, possibly, other  $XYZ$  mesons). In near-threshold production experiments in the  $\sqrt{s_{pN}} \simeq 8$  GeV energy range,  $X(3872)$  mesons can be produced with typical c.m.s. kinetic energies of a few hundred MeV (*i.e.*, with  $\gamma\beta \simeq 0.3$ ). In the case of the  $X(3872)$ , its decay length will be greater than 50 fm while the distance scale for the  $c\bar{c} \rightarrow D^0\bar{D}^{*0}$  transition would be  $2 \sim 3$  fm. Since the survival probability of an  $r_{\text{rms}} \sim 9$  fm “molecule” inside nuclear matter should be very small,  $X(3872)$  meson production on a nuclear target with  $r_{\text{rms}} \sim 5$  fm or more ( $A \sim 60$  or larger) should be strongly quenched (see Fig. 2). Thus, if this hybrid picture is correct, the atomic number dependence of  $X(3872)$  production at fixed  $\sqrt{s_{pN}}$  should have a dramatically different behaviour than that of the  $\psi'$ , which is a long-lived compact charmonium state.

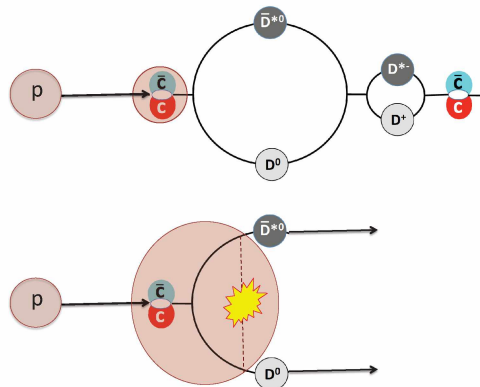

Figure 2: **(Top)**  $X(3872)$  production on a proton target ( $r_{\text{rms}} \simeq 1$  fm). Here the  $X(3872)$  escapes the target region before it establishes a significant  $D\bar{D}^*$  component. **(Bottom)**  $X(3872)$  production on a nuclear target. Here the presence nuclear material disrupts the ( $< 200$  keV) coherence between the well separated  $D^0$  and  $D^{*0}$  (represented by the dashed line).

In this talk we will summarize the current experimental status of the  $XYZ$  mesons and hidden-charm pentaquark candidates and present simulations of what we might expect from a study of the  $A$ -dependence of  $X(3872)$  meson production at NICA.

## References

- [1] See, for example, S.L. Olsen, *Front. Phys.* **10**, 101401 (2015).
- [2] S. Takeuchi, K. Shimizu and M. Takizawa, *Prog. Theor. Exp. Phys.* **2015**, 079203 (2015).
- [3] A. Esposito, A. Pilloni and A.D. Polosa, arXiv:1603.07667 [hep-ph].
- [4] Here we use  $\chi_{c2}(2P)$ - $\chi_{c1}(2P)$  mass splitting computed by S. Godfrey and N. Isgur, *Phys. Rev. D* **32**, 189 (1985) and scale the  $\chi_{c1}(2P)$  mass from the measured  $\chi_{c2}(2P)$  mass reported in K.A. Olive *et al.* (PDG), *Chin. Phys. C* **38**, 090001 (2014).
- [5] The width of the  $X(3872)$  is experimentally constrained to be  $\Gamma_{X(3872)} < 1.2$  (90% CL) in S.-K. Choi *et al.* (Belle Collaboration), *Phys. Rev. D* **84**, 052004 (2011).

# FIELD INDUCED PHASE TRANSITION IN THE FEW-PHOTON REGIME

A.D. Panferov<sup>1†</sup>, S.A. Smolyansky<sup>1</sup>, A.I. Titov<sup>2</sup>, B. Kämpfer<sup>3,4</sup>, A. Otto<sup>3,4</sup>, and D.B. Blaschke<sup>2,5,6</sup>

(1) *Saratov State University, RU - 410026 Saratov, Russia*

(2) *Bogoliubov Laboratory for Theoretical Physics, Joint Institute for Nuclear Research, RU - 141980 Dubna, Russia*

(3) *Institute of Radiation Physics, Helmholtz-Zentrum Dresden-Rossendorf, Bautzner Landstrae 400, 01328 Dresden, Germany*

(4) *Institut für Theoretische Physik, Technische Universität Dresden, Zellescher Weg 17, 01062 Dresden, Germany*

(5) *Institute for Theoretical Physics, University of Wrocaw, 50-204 Wrocaw, Poland*

(6) *National Research Nuclear University (MEPhI), RU - 115409 Moscow, Russia*

† *E-mail:smol@sgu.ru*

The few-photon regime of the vacuum excitations of the electron - positron plasma (EPP) attracts attention in connection with perspectives of the experimental observation of the dynamical Schwinger effect [1, 2, 3]. In this regime the characteristic times of the processes are comparable to the Compton time, and the transient process of the fast oscillations is smoothed in comparison with the tunnel regime. The pair production probability undergoes a resonant growth with increasing power of the external field photons. The rest features of the field induced phase transition (strong non-equilibrium of the produced EPP and nonmonotonic growth of the entropy [4]) remain in the few-photon region. Also, we present some analytical estimates of the distribution function in the one-photon approximation.

## References

- [1] A. D. Panferov, S. A. Smolyansky, A. Otto, B. Kämpfer, D. B. Blaschke, and L. Juchnowski, *Eur. Phys. J. D* **70**, 1 (2016)
- [2] A.I. Titov, B. Kämpfer, A. Hosaka, and H. Takabe, *Phys. Part. Nucl.*, **47**, 835 (2016).
- [3] T. Nousch, A. Otto, D. Seipt, B. Kämpfer, A.I. Titov, D. Blaschke, A.D. Panferov, S.A. Smolyansky, arXiv:1604.00201.
- [4] S.A. Smolyansky, A.D. Panferov, D.B. Blaschke, L. Juchnowski, B. Kämpfer, A. Otto, arXiv:1607.08775.

# STUDY OF NEUTRON SPECTRA IN EXTENDED URANIUM TARGET

## NEW EXPERIMENTAL DATA

M. Paraipan<sup>1,2</sup>

E&T collaboration

<sup>1</sup>*Joint Institute for Nuclear Research, Dubna, Russia*

<sup>2</sup>*Institute of Space Science, Bucharest-Magurele, Romania*

The spatial distribution of neutron fluences in the extended uranium target ("Quinta" assembly) irradiated with 0.66 GeV proton, 4 AGeV deuteron and carbon beams was studied using the reactions with different threshold energy ( $E_{th}$ ). One data set was obtained with <sup>59</sup>Co samples. The accumulation rates for the following isotopes: <sup>60</sup>Co ( $E_{th}$  0 MeV), <sup>59</sup>Fe ( $E_{th}$  3 MeV), <sup>58</sup>Co ( $E_{th}$  10 MeV), <sup>57</sup>Co ( $E_{th}$  20 MeV), <sup>56</sup>Co ( $E_{th}$  32 MeV), <sup>47</sup>Sc ( $E_{th}$  55 MeV), and <sup>48</sup>V ( $E_{th}$  70 MeV) were measured with HPGe spectrometer. The additional data set was measured in the fission reactions with <sup>nat</sup>U ( $E_{th}$  1 MeV) samples. The measured data on neutron energy spectra are well parameterized by a function with four Maxwellian components. The experimental accumulation rates and the reconstructed neutron spectra were compared with the predictions of the simulations with Geant4 code. Substantial difference between the reconstructed and the simulated data for the hard part of the neutron spectrum was analyzed.

# ULTRARELATIVISTIC TRANSVERSE MOMENTUM DISTRIBUTION OF THE EXACT TSALLIS STATISTICS

A.S. Parvan<sup>†</sup>

*Bogoliubov Laboratory of Theoretical Physics, Joint Institute for Nuclear Research, Dubna,  
Russian Federation*

*Department of Theoretical Physics, Horia Hulubei National Institute of Physics and Nuclear  
Engineering, Bucharest-Magurele, Romania*

*<sup>†</sup> E-mail: parvan@theor.jinr.ru*

The analytical expression for the ultrarelativistic transverse momentum distribution of the Tsallis statistics was obtained and applied to describe the experimental data on the transverse momentum distributions of hadrons measured in  $pp$  collisions at LHC and RHIC energies. We found that the transverse momentum distribution of the Tsallis-factorized statistics, which is now largely used for the description of the experimental transverse momentum spectra of hadrons at high energies, in the ultrarelativistic case is equivalent to the transverse momentum distribution of the Tsallis statistics in the zeroth term approximation with transformation of the parameter  $q$  to  $1/q_c$ . Moreover, we demonstrated that the Tsallis-factorized statistics is different from the Tsallis statistics. We also considered the energy dependence of the parameters for both the Tsallis statistics and its zeroth term approximation for the pions produced in  $pp$  collisions at high energies and found that the results of the zeroth term approximation deviate from the results of the Tsallis statistics only at low NA61/SHINE energies when the value of the parameter  $q$  is close to unity. At higher energies, when the value of the parameter  $q$  deviates essentially from the unity, the zeroth term approximation satisfactorily recovers the results of the Tsallis statistics.

# FOUNDATIONS OF A UNIFIED PHYSICS

Ivanhoe B.Pestov<sup>1†</sup>

(1) *Bogoliubov Laboratory of Theoretical Physics, Joint Institute for Nuclear Research, 141980  
Dubna, Moscow Region, Russia*

† *E-mail: pestov@theor.jinr.ru*

The creation of a unified geometrical theory of fundamental interactions is motivated by two severe constraints. It is natural to suppose that solution of the fundamental physical problems cannot be given without a more drastic revision of our fundamental concepts than any that have done before. Quite likely these innovations are so great that direct attempts to derive new ideas from experimental data will be beyond the power of human intelligence. And second, we need to know the origin of the laws and, hence, to formulate a new theory which considers world as a whole (as an integral structure) and gives a possibility to understand why nature is just the way it is. To produce a single theory that provides understanding of the structure of our universe as a unique possible consequence of the only simple assumption (a first principle), we abstract away from the known concepts and laws and put forward the fundamental principle of unification which can be presented in the form of the grand relation: fundamental physical ideas, symmetries and equations are tightly connected with the idea of space and, hence, they have the geometrical origin and are formulated in the form completely independent of any outer and a priori conditions (everything in the concept of space and the concept of space in everything). Thus, the radically new idea of a unified physics is a most possible generality and the outlined first principle. The theory presented is the only one unique logically possible physical theory since it gives the solution of the most difficult and long-standing problem in the history of science - the problem of time. A new concept of time provides the formulation of the law of energy conservation (the most fundamental law of the nature) in the form which is the most general and, hence, suitable for all cases without exclusion. When we discover connections of time with another objects, the reason of the existence of time becomes clear.

The formulated theory provides opportunity to understand the origin and nature of physical fields and local internal symmetry; time and energy; spin and charge; confinement and quark-lepton symmetry; dark energy and dark matter, giving by this solution of the fundamental physical problems and conforming together with this the existence of new physics in its unity [1, 2, 3, 4, 5, 6, 7, 8].

## References

- [1] I.B. Pestov. In: *Horizons in World Physics, Vol.248*, Ed. by A. Reimer, (Nova Science, New York, 2005), p.1; Preprint No.E2-2004-105 JINR (Dubna, 2004); gr-qc/0507131.
- [2] I.B.Pestov, *New concept of time and gravity*, In: *Symmetries and Intergrable Systems, Vol. II*, Ed. by A.N. Sissakian; Preprint No. E2-96-424, JINR (Dubna, 1996).

- [3] I.B.Pestov, Physics of Atomic Nuclei, Vol. **74**, n.7, 1084 (2011); Preprint No. E2-2008-93, JINR (Dubna, 2008).
- [4] I.B.Pestov, J.Phys. A: Math.Gen. **33**, 3027 (2000).
- [5] I.B. Pestov. In: *Dark Matter: New Research*, Ed. by Val Blain (Nova Science, New York 2006), p. 77; Preprint No. E2-2005-51, JINR (Dubna, 2005); gr-qc/0412096.
- [6] I.B. Pestov. Physics of Particles and Nuclei, Vol. **44**, No.3, 442 (2013).
- [7] I.B. Pestov, Theor. and Math. Phys. **34(1)**, 48 (1978).
- [8] I.B. Pestov (2015) Foundations of a Unified Physics. J Phys Math 6: 135. doi: 10.4172/2090-0902.1000135



## SIZE AND DISTANCE IN HIGH-ENERGY PHYSICS

V.A. Petrov

*Institute for High Energy Physics  
NRC "Kurchatov Institute"  
Protvino, Russian Federation*

In spite of the apparent dominance of the energy-momentum variables in formulating models of the high-energy hadron interaction the use of the spatio-temporal arguments remains an important part both of general theoretical reasoning and phenomenological interpretation of the experimental data. Such quantities as "charge radius" of nucleon, pion and kaon are among the most important particle characteristics contained in the Particle Data Group volumes. "Interaction radius" is routinely estimated from the data on high-energy elastic scattering via the extraction of the "forward slope". The Bose-Einstein correlations of the like-charge pions are interpreted in terms of the size of the region where these pions are being radiated from.

Being quite appealing and spectacular in non-relativistic quantum mechanics the use of the space-time notions in the relativistic domain where instantaneous potentials cease to be relevant reveals serious problems related with generally non-negligible retardation (causal) effects and composite structure of interacting particles.

In the talk we exhibit the problem in terms of the relativistic quantum field-theoretic notions which helps to better understand the real physical content of the spatial quantities used for the description and interpretation of the high-energy collision events.



# MONTE CARLO MODELING OF NEUTRON GENERATION AND PROPAGATION IN URANIUM TARGET IRRADIATED WITH DEUTERON BEAM OF ENERGY FROM 1 GEV UP TO 8 GEV.

Aleksander Polański

*National Centre for Nuclear Research, Otwock-Świerk, Poland.*

The results of calculations of generation and transport of neutrons produced in uranium during irradiations deuterons beam with energies up to 4 GeV/nuc are presented.

We have compared results of calculations with experiments which refer to the study of high energy neutron spectra at various points in the volume of the Quinta assembly.

The cross sections of the interactions of elastic and nonelastic secondary particles, ie neutrons, protons and pi-mesons with the nuclei of U-238, U-235 and Pb were used from barpol.dat from LAHET data.

In the next step the cross sections for the generation of neutrons in uranium during the interactions of neutrons and protons with energies in the range of energies from 10 MeV up to 4 GeV were calculated. The part of neutrons resulting from the fission of nuclei of uranium-238 and uranium 235 irradiated with neutrons and protons of an energy from 10 MeV up to 4 GeV was calculated.

Designated cross sections were used to calculate the energy spectra of neutrons inside the Quinta set-up exposed by beams of deuterons in the energy range up to 4 GeV/nuc. The calculation results were compared with experimental data obtained using the threshold detectors and gamma spectroscopy.

Fig. 1. presents the results of calculations of neutron spectra in range from 10 MeV up to 100 MeV and comparison with the experiment data in which the Quinta target with lead reflector was irradiated with a pulsed deuteron beam of energy 4 GeV. The Y-89 activation detectors were placed in the Quinta setup on the detector plates (4 and 5), between the uranium sections in two positions at varying radial distances (4 and 8 cm; see Fig. 1 ) from the beam axis. Using the experimental data we evaluated the average neutron flux (dFlux/dE) per one deuteron for the three energy ranges (11.5 - 20.8) MeV, (20.8 - 32.7) MeV and (32.7 – 100) MeV of neutrons. Results of calculations using various interaction models were compared with experimental data obtained with itrium detectors in different positions within the set -up of Quinta.

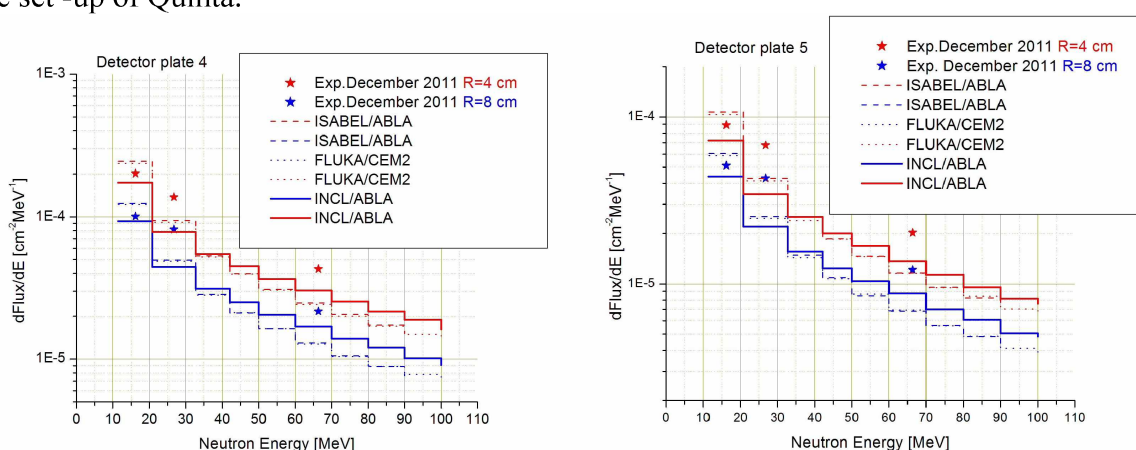

**Fig. 1** Neutron flux spectrum in the energy range 10-100 MeV at R=4 cm and R=8 cm on detector plates 4 and 5 .

As shown in the Fig.1. obtained experimental data are larger than the calculated data, especially for neutrons with energies higher than 20 MeV.

# ELECTROWEAK PROPERTIES OF $\rho$ -MESON IN THE INSTANT FORM OF RELATIVISTIC QUANTUM MECHANICS

A.F. Krutov<sup>1†</sup>, R.G. Polezhaev<sup>1‡</sup> and V.E. Troitsky<sup>2\*</sup>

(1) *Samara University, 443086 Samara, Russia*

(2) *D.V. Skobeltsyn Institute of Nuclear Physics, Moscow State University, Moscow 119991, Russia*

† *E-mail: krutov@samsu.ru*

‡ *E-mail: polezaev@list.ru*

\* *E-mail: troitsky@theory.sinp.msu.ru*

Electromagnetic form factors, mean-square radius, magnetic and quadrupole moments of the  $\rho$ -meson are calculated in framework of the developed by authors version of the instant form of relativistic quantum mechanics with fixed number of particles (RQM) [1]. The calculations are performed with different wave functions of quarks in the  $\rho$ -meson and using the so called modified impulse approximation (MIA). MIA is formulated in a relativistically invariant way and with account of the conservation law for electromagnetic current. In present work the general method of parameterization of the matrix elements of local operators is used for the construction of the electroweak currents [1, 2]. The parameters of our relativistic constituent quark model are fixed from the calculations of electroweak properties of the pion [3] and from the experimental values of lepton decay constant of the  $\rho$ -meson:  $f_\rho = 152 \pm 8$  MeV [4]. So, the calculations of the above electromagnetic characteristics of  $\rho$ -meson are performed without fitting parameters. Our formulation of the instant form of RQM gives the self-consistent description of the electroweak properties of the pion and  $\rho$ -meson. Obtained in this work the mean-square radius of the  $\rho$ -meson  $\langle r_\rho^2 \rangle = 0.56 \pm 0.04$  fm<sup>2</sup> satisfies the hypothesis of Ref. [5] about equality of the electric and strong radius of hadrons which is confirmed for the pion, kaon and proton [6]. The result of the calculation of the magnetic moment of the  $\rho$ -meson describes well the available experimental data:  $\mu_\rho = 2.1 \pm 0.5 e/2M_\rho$  [7]. In our approach the behavior of the pion and  $\rho$ -meson electromagnetic form factors depends on the choice of wave functions weakly and is mainly determined by the mass of the constituent quarks.

## References

- [1] A.F. Krutov and V.E. Troitsky, *Phys. Part. Nucl.* **40**, 136 (2009).
- [2] A.F. Krutov, R.G. Polezhaev, V.E. Troitsky, *Theor. Math. Phys.* **184**, 1148 (2015).
- [3] A.F. Krutov and V.E. Troitsky, *Eur. Phys. J. C.* **20**, 71 (2001); [hep-ph/9811318].
- [4] K.A. Olive *et.al.* (Particle Data Group), *Chin. Phys. C.* **38**, 090001 (2014).
- [5] T.T. Wu and C.N. Yang, *Phys. Rev. B.* **137**, 708 (1965).
- [6] B. Povh, J. Hüfner, *Phys. Lett. B.* **245**, 653 (1990).
- [7] D. Garcia Gudino, G. Toledo Sanchez, *J. Mod. Phys. A.* **30**, 1550114 (2015).

# RECENT HEAVY ION RESULTS FROM THE ATLAS EXPERIMENT

M. Przybycien<sup>1</sup>

<sup>1</sup>ATLAS Collaboration

The ATLAS experiment at the Large Hadron Collider has undertaken a broad physics program to probe and characterize the hot nuclear matter created in relativistic lead-lead collisions. This talk presents recent results on production of jet, electroweak bosons and quarkonium, electromagnetic processes in ultra-peripheral collisions, and bulk particle collectivity from PbPb and pPb collisions.

# OVERVIEW OF ALICE RESULTS IN pp, pA AND AA COLLISIONS

R. Schicker on behalf of the ALICE collaboration

*Phys. Inst., Univ. Heidelberg*

The ALICE experiment at the Large Hadron Collider (LHC) at CERN is optimized for recording events in the very large particle multiplicity environment of heavy-ion collisions at LHC energies. The ALICE collaboration has taken data in lead-lead collisions in Run 1 and Run 2 at nucleon-nucleon center-of-mass energies  $\sqrt{s_{nn}} = 2.76$  and 5.02 TeV, respectively, and in proton-proton collisions at center-of-mass energies  $\sqrt{s}=0.9, 7,8$  and 13 TeV. The asymmetric system proton-lead was measured at a center-of-mass energy  $\sqrt{s_{nn}} = 5.02$  TeV. I will discuss some selected physics results from the analysis of these data, and outline the ALICE prospects for Run 3.

# ELASTIC EVENTS SELECTION IN INTERACTIONS OF THE COLLIDING $pp$ AND $dd$ BEAMS OF THE NICA COLLIDER

V.I. Sharov<sup>†</sup>

*Veksler and Baldin Laboratory of High Energy Physics, Joint Institute for Nuclear Research, Dubna, Russia*

<sup>†</sup> *E-mail: vsharov41@mail.ru*

In our previous reports and publications [1-3] we have considered the possibilities of studies of the spin observables for particles with spin 1/2 and 1 in the elastic interactions of colliding proton and deuteron beams of the NICA collider [4]. It was shown that in elastic interactions of colliding proton beams there can be measured: a) differential cross section  $d\sigma/d\Omega^0(E_{CM}, \theta_{CM}) = I_{0000}(E_{CM}, \theta_{CM})$  with unpolarized protons, b) analyzing powers for reactions with one polarized colliding beam  $A_{00n0}(E_{CM}, \theta_{CM})$  or  $A_{000n}(E_{CM}, \theta_{CM})$ , and c) the spin correlation parameters  $A_{00kk}(E_{CM}, \theta_{CM})$  and  $A_{00nm}(E_{CM}, \theta_{CM})$  in interactions of the both polarized colliding proton beams. In elastic interactions of the colliding deuteron beams one can obtain a complete set of energy and angular dependencies of components of the vector and tensor analyzing powers  $A_y(E_{d,CM}, \theta_{d,CM})$ ,  $A_{yy}(E_{d,CM}, \theta_{d,CM})$ , and  $A_{xx}(E_{d,CM}, \theta_{d,CM})$  for the  $dN$  and  $dd$  reactions in the energy region of the colliding  $dd$  beams of the NICA collider. The planned luminosity of the polarized colliding  $pp$  and  $dd$  beams will allow us to obtain in such measurements sufficiently high counting rate of elastic events.

To get the value of the spin-dependent  $pp$ ,  $pd$  or  $dd$  observables it is necessary to measure the asymmetry of the outputs of the processes under study, that is, the ratio of the difference and sum of elastic cross sections with opposite signs of polarization of the colliding particles (or right-left asymmetries for the same sign of polarization). In the present report we discuss in more detail the kinematic characteristics of the elastic  $pp$ ,  $pd$  and  $dd$  scattering processes in the collider system and certain matters relating to registration and selection of elastic  $pp$ ,  $pd$  and  $dd$  events.

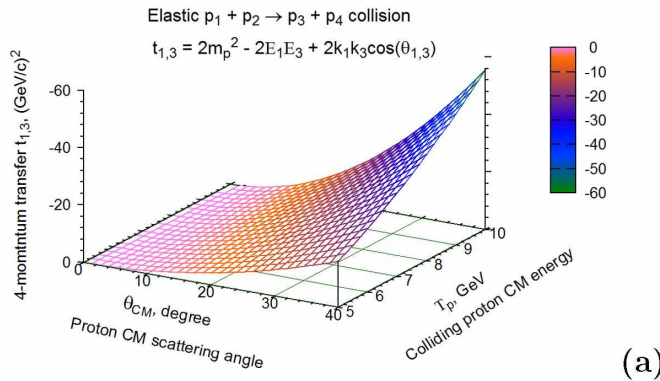

Figure 1 (a) Complete representation of the kinematics of the elastic  $pp$  collisions in the collider.

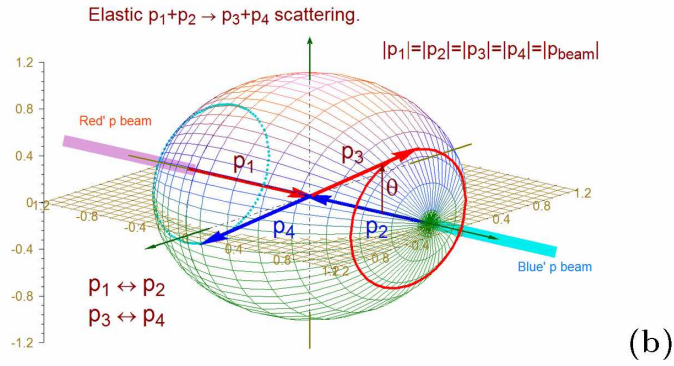

Figure 1 (b) 3D range of possible values and orientations of the particle momentum in elastic  $pp$  collision at collider.

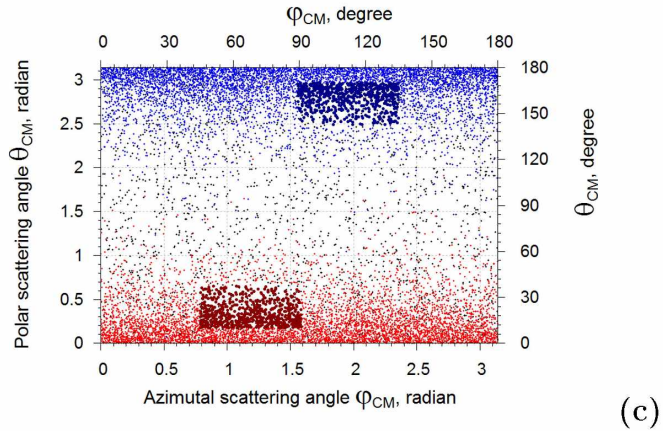

Figure 1 (c) Monte carlo simulation of the elastic  $p_1 + p_2 \rightarrow p_3 + p_4$  collisions at collider in  $\theta, \phi$  region.

## References

- [1] V.I. Sharov, Possibilities for the Spin-Dependent Observables Measurement in Elastic NN Scattering at NICA. In Proceedings of "XV Advanced Research Workshop on High Energy Spin Physics. (DSPIN-13)", Dubna, October 8-12, 2013. Dubna, JINR, E1,2-2014-12, 2014, p. 367-370.
- [2] V.I. Sharov, Measurement of the Spin-Dependent Observables in Elastic NN Collisions at NICA. In Proceedings of "XXII International Baldin Seminar on High Energy Physics Problems. Baldin ISHEPP XXII", Dubna, September 15-20, 2014. <http://pos.sissa.it/>, *PoS(Baldin ISHEPP XXII)102*.
- [3] V.I. Sharov, Possible measurements of the spin one observables in elastic dN, dd collisions at the NICA deuteron beams. In Proceedings of "XVI Workshop on High Energy Spin Physics (D-SPIN2015). Dubna, September 15-20, 2014, Journal of Physics: Conference Series 678 (2016) 012011. <http://iopscience.iop.org/issue/1742-6596/678/1;jsessionid=683828FCC016CC0ACD9BFF02EA93C013.c5.iopscience.cld.iop.org>
- [4] NICA - Nuclotron - based Ion Collider fAcility - a Base for Fundaventional Research and Innovation Development, JINR, Dubna 2014. <http://nica.jinr.ru/files/Booklet-NICA.pdf>

# FORM FACTORS IN THE CLOTHED-PARTICLE REPRESENTATION

A.V. Shebeko

*Kharkov Institute of Physics & Technology, Ukraine*

† *E-mail: shebeko@kipt.kharkov.ua*

The method of unitary clothing transformations (UCTs) ([1]–[5]) allows us to develop an alternate approach for calculating the matrix elements  $F^\mu(p', p) \equiv \langle p'; out | J^\mu(0) | p; in \rangle$  of the Nöther current density operator  $J^\mu(0)$  sandwiched between the *in(out)* states of interacting fields. Since every UCT  $W(\alpha_c) = W(\alpha) = \exp R$ ,  $R = -R^\dagger$  connects a primary set  $\alpha$  of creation (annihilation) operators in the bare-particle representation (BPR) with new operators  $\alpha_c$  in the clothed-particle representation (CPR) via similarity transformation  $\alpha = W(\alpha_c)\alpha_c W^\dagger(\alpha_c)$ , we consider the expansion

$$J^\mu(0) = W J_c^\mu(0) W^\dagger = J_c^\mu(0) + [R, J_c^\mu(0)] + \frac{1}{2}[R, [R, J_c^\mu(0)]] + \dots,$$

where  $J_c^\mu(0)$  is the initial current in which the bare operators are replaced by their clothed counterparts. Along this guideline we have to handle  $R$ -commutators  $[R, [R, \dots [R, J]]] \equiv J^{[n]}$  with  $n$  brackets. As an illustration of the recursive procedure proposed in [3] for calculations with similar multiple commutators, we will show our results in case of the electromagnetic current operator of meson-nucleon system  $J^\mu(0) = J_N^\mu(0) + J_\pi^\mu(0) + J_\rho^\mu(0) + J_\omega^\mu(0) + \dots$  and in quantum electrodynamics (qed) with  $J^\mu(0) = J_e^\mu(0) = \frac{1}{2}[\bar{\psi}(0), \gamma^\mu \psi(0)] =: \bar{\psi}(0)\gamma^\mu\psi(0)$  ;, where  $\psi(0)$  is electron-positron field  $\psi(x)$  at  $x = (0, \vec{0})$ . In both cases the matrix elements of interest between one-fermion states  $|p; in\rangle = |p; out\rangle = b_c^\dagger(p)|\Omega\rangle$  with the 4-momentum  $p = (p_0, \vec{p})$ ,  $p_0 = \sqrt{\vec{p}^2 + m^2}$  are expressed through the Dirac  $F_1(q^2)$  and Pauli  $F_2(q^2)$  form factors that depend on the 'transferred' 4-momentum  $q = p' - p$  squared, viz.,

$$F^\mu(p', p) = e\bar{u}(p')\{F_1(q^2)\gamma^\mu + i\sigma^{\mu\nu}F_2(q^2)(p' - p)_\nu\}u(p)$$

Other notations embody the one-clothed fermion (electron, nucleon) creation operator  $b_c^\dagger(p)$ , fermion mass  $m$  and physical vacuum state  $|\Omega\rangle$ . All polarization indices are implied. In my opinion, such a way can be helpful when calculating higher-order radiative corrections in mesodynamics, qed and other field models.

## References

- [1] A.V. Shebeko and M.I. Shirokov, *Progr. Part. Nucl. Phys.* **44**, 75 (2000).
- [2] V.Yu. Korda and A.V. Shebeko, *Phys. Rev. D* **70** 085011 (2004).
- [3] V.Yu. Korda, L. Canton and A.V. Shebeko, *Ann. Phys.* **322**, 736 (2007).
- [4] I. Dubovyk and A. Shebeko, *Few Body Syst.* **48** 109 (2010).
- [5] A. Shebeko, Chapter 1 In: *Advances in Quantum Field Theory*, ed. S. Ketov, 2012 InTech, pp. 3-30.

## **FOUR ALL NN-SCATTERING AMPLITUDES**

R.A. Shindin, A.N. Livanov et al.

*JINR LPHE*

Using the standard of NN-scattering definition we obtain new presentation of four scattering amplitudes included the finite spins states of two nucleons.



# PHENOMENOLOGICAL DESCRIPTION OF SPIN EFFECTS IN ELECTROMAGNETIC AND STRONG INTERACTIONS OF QUARKS

A.J. Silenko<sup>1,2</sup>, O.V. Teryaev<sup>1,3</sup>

1. *Joint Institute for Nuclear Research, 141980 Dubna, Moscow region, Russia*
2. *Research Institute for Nuclear Problems, Belarusian State University, 220030 Minsk, Belarus*
3. *National Research Nuclear University "MEPhI" (Moscow Engineering Physics Institute), 115409 Moscow, Russia*

A phenomenological description of interaction of relativistic quarks is given in framework of the Dirac equation with the Cornell potential. The general initial equation containing the vector and scalar parts of the Cornell potential is used. Any simplifying assumptions about a connection between these parts [1-7] are not made. The relativistic Hamiltonian in the Foldy-Wouthuysen representation is derived in the general form with allowance for the electromagnetic interaction. Unlike previous investigations [1-7], it is exact for terms of the zeroth and first orders in the Planck constant,  $\hbar$ , and for terms of the second order in  $\hbar$  describing contact interactions. General quantum-mechanical equations of motion are deduced for the momentum and spin and their classical limit is obtained. The connection between the angular velocity of the spin precession and the force acting on the quark is determined. The obtained energy of the spin-orbit interaction is of the order of 100 MeV. The spin-spin interaction of the quarks is also calculated. The work is supported by the FFI RB – JINR grant No.  $\Phi$ 16D-004.

## REFERENCES

1. U. D. Jentschura, J. H. Noble // *J. Phys. A: Math. Theor.* – 2014. – V. 47. – P. 045402.
2. H. Hassanabadi, E. Maghsoodi, S. Zarrinkamar, H. Rahimov // *Adv. High Energy Phys.* – 2012. – V. 2012. – P. 707041.
3. H. Hassanabadi, E. Maghsoodi, S. Zarrinkamar // *Ann. Phys. (Berlin)*. – 2013. – V. 525. – P. 944.
4. M. Hamzavi, A.A. Rajabi // *Ann. Phys. (New York)*. – 2013. – V. 334. – P. 316.
5. M. Hamzavi, A.A. Rajabi // *Chin. Phys. C.* – 2013. – V. 37. – P. 103102.
6. A.A. Rajabi, M. Hamzavi // *Few-Body Syst.* – 2013. – V. 54. – P. 2067.
7. L.A. Trevisan, C. Mirez, F.M. Andrade // *Few-Body Syst.* – 2014. – V. 55. – P. 1055.

# SCALING AND CORRELATIONS IN ELECTROMAGNETIC CASCADES PRODUCED BY GAMMA QUANTA IN DENSE AMORPHOUS MEDIA

B. Słowiński<sup>1,2</sup>, P. Duda<sup>2</sup>, J. Bzdak<sup>2</sup>, D. Mączka<sup>1</sup>

<sup>1</sup>*National Centre for Nuclear Research, Świerk, Poland*

<sup>2</sup>*Faculty of Physics, Warsaw University of Technology, Poland*

The electromagnetic cascade (ELM) induced by high energy electrons and gamma quanta (GQ) in heavy amorphous materials has been the first stochastic phenomenon discovered in physics and its investigation is conducted for over fifty years (for example, [1,2]). Nevertheless, we have so far in practice fragmentary information on it only although up to about 100 GeV ELM consists of elementary effects of pure electromagnetic nature which are studied very well. The point is that our rather simple knowledge of ELM seems to be sufficient for several important practical purposes, in particular, for the detection of electrons and GQ at least at the available accuracy of measurements and for radiation protection from GQ. For these purpose it is enough usually to know two following characteristics of ELM: the longitudinal profile (LP) of energy deposition and its relative dispersion because at high energies ( $\geq 100$  MeV) ELM develops mostly in the direction of impinging particles. Nevertheless, other features of ELM are also of great importance. First of all they are as follows: the correlation in the longitudinal cascade development (CLP), transverse profile (TP) and its fluctuation, correlation between LP and TP along the direction of the cascade development and the relevant fluctuation.

To show how important is, for example, a thorough knowledge of CLP it is enough to take into account that the depth  $t$  up to which practically all energy of ELM is released in the material, depends on energy  $E$  of primary electrons or GQ as  $t \sim \ln E$ . But the dimensions of detectors usually not exceed 20 radiation lengths. Moreover, a free path of GQ fluctuates as well causing a cut-off effect of created ELM. So, to reconstruct the true value of  $E$  it remains nothing more than to use the correlation of energy release in the cascade layers before some limiting cascade depth in the material. Moreover, a simple 3-parameter LP description needs further refinements both at the ELM beginning and its end too, and we suggest to make this by means of a 5-parameter formula.

We report the results of investigation of LP produced by GQ of energy from 100 MeV to 11 GeV in four most frequently used materials (BGO, PWO, liquid Xe and lead glass) and the relevant fluctuation and correlation. The work has been performed using GEANT4 modeling code. The aim of our investigation is to find a practically convenient and simple form of LP scaled both with energy  $E$ , cut-off energy and material's properties. Moreover, we have also obtained useful information about CLP.

## References:

1. B. Słowiński. Phys. Part. Nucl. 25 (2) March-April 1994, pp.173-209; Radiat.Phys.Chem. V.49, No.3, pp.327-329, 1997.
2. Konrad Kleinknecht. Detectors for particle radiation. Cambridge University Press. London-New York-New Rochelle-Melbourne-Sydney, 1986; C.Grupen. Particle detectors. Cambridge University Press. 1996; Dan Green. The Physics of Particle Detectors. Cambridge University Press.2000; Review of Particle Physics. W.-M. Yao, et al., Journal of Physics G33, 1 (2006).
3. B. Słowiński, P.Duda, D.Mączka and J.Bzdak. Proceedings of Science. PoS (Baldin ISHEPP XXI) 080. 2012. <http://pos.sissa.it>.



## QUASI-TWO-BODY PION-NUCLEUS COLLISIONS AT THE GeV ENERGY REGION AS AN INTRANUCLEAR SPACE PROBE

B.Słowiński<sup>1,2</sup>, A.Pacan<sup>2</sup>, A.Malakhov<sup>3</sup>, R.Korzeniowski<sup>2</sup>

<sup>1</sup>*National Centre for Nuclear Research, Świerk, Poland*

<sup>2</sup>*Faculty of Physics, Warsaw University of Technology, Poland*

<sup>3</sup>*Joint Institute for Nuclear Research, Dubna, Russia*

It was made evident even for an enough long time that the nucleus consists not only of simply nucleons but it also contains several nontrivial ingredients (for example, [1]). However, the revelation of such components or degrees of freedom is conditioned by the resolution in space and time of the investigation approach used for probing the nucleus. For these purposes applied are as a probe the electrons (for example, [2]) because they have rather long mean free-path in nuclear matter and pions as the lightest hadrons. Moreover, the wave length of pions with energy of above 1 GeV is as short as  $\leq 0.3$  fm, i.e. appreciably less than the average distance between nucleons inside nuclei ( $\sim 1.8$  fm) and therefore it is possible this way to resolve intranuclear structures.

Suitable tools for probing the nucleus are quasi-two-body channels of interactions such as

$$\pi + A \rightarrow \pi + X + (\pi^{+/-0}, p, n) \quad (1)$$

at the GeV energy region, where A is the investigated target nucleus, X is the knocked out particle whereas in brackets are shown the possible background particles which are not visible by detectors. But to make a geometrical snapshot of such reactions it is necessary to know the impact parameter (IP) which is immeasurable quality but it determines the initial geometry of interaction.

Previously [3] we have studied the correlation between multiplicity (M), rapidity (R) and IP of charged pions, protons and neutrons produced in  $\pi + \text{Xe}$  interactions at several GeV energies by means of JAM modeling code and found that there exists practically meaningful correlation between IP and both the average multiplicity and average rapidity of produced particles. Therefore, using such correlations between the observables (M, R and in addition the transverse momentum - Pt) and IP one can estimate (within available statistical spreading because the shown above reaction has a stochastic character) the location from where the object X has been knocked out. So, using experimental information about R and Pt of particles X emitted in quasi-two-body channels of  $\pi + A$  reactions it is in principle possible to infer, to some extent, what was the IP of a primary  $\pi$ -meson hitting the nucleus target.

In the present work we investigate using JAM modeling code the distributions in 1D, 2D and 3D configuration spaces of (R, Pt, IP) of secondary  $\pi^0$  and  $\eta^0$  emitted in the quasi-two-particle's reaction (1) at 2.34, 3.5 and 9 GeV/c of primary pions. The obtained results provides reason to conclude that about 50% of such interactions take place at  $\text{IP} \approx 6 \pm 1$  fm around its maximum value in the Xe target nucleus within all investigated GeV energy region which coincides with our previous analytical estimation [4]. Moreover, an interesting experimental observation of kinematic collimation of secondary neutral pions emitted in (1) as if they are produced on an intranuclear effective target of pion's mass [5] is also reported.

### References

- [1]. T.Ericson and W.Weise. Pions and Nuclei. Clarendon Press, Oxford. 1988.
- [2]. V.G.Neudatchin, I.T.Obukhovskiy, L.L.Sviridova, N.P.Yudin. Nucl. Phys. A 739 (2004) 124-150.
- [3]. B.Słowiński, R.Korzeniowski and R.Sobczak. NIM A 694(2012)280-5.
- [4]. B.Słowiński. Sov. J. Nuc. Phys., 1974,v.19,N.3,p.301.
- [5] B.Słowiński. In: Hadron Physics. Scottish Graduate Series. Taylor & Francis. New York London, 2006, p.425.

# RESIDUAL CURRENTS GENERATED FROM VACUUM BY AN ELECTRIC FIELD PULSE IN 2+1 DIMENSIONAL QED MODELS

S.A. Smolyansky<sup>1†</sup>, D.V. Churochkin<sup>1</sup>, V.V. Dmitriev<sup>1</sup>, A.D. Panferov<sup>1</sup>, B. Kämpfer<sup>2,3</sup>

(1) *Saratov State University, RU - 410026 Saratov, Russia*

(2) *Institute of Radiation Physics, Helmholtz-Zentrum Dresden-Rossendorf, Bautzner Landstrae 400, 01328 Dresden, Germany*

(3) *Institut für Theoretische Physik, Technische Universität Dresden, Zellescher Weg 17, 01062 Dresden, Germany*

† *E-mail:smol@sgu.ru*

In the present work we investigate the conductivity and polarization currents in 2+1 dimensional QED (standard variant and graphene) on the basis of the kinetic equation obtained on the nonperturbative basis by analogy with the 3+1 QED [1]. The transition to the quasiparticle representation is accomplished on the basis of the unitary matrices which can be cast in an explicit form [2]. We use the super-Gauss models of the external electric field with sharp fronts. The result of numerical solutions of the problem exhibits that the residual polarization current survives during the macroscopical period, as also the damping oscillations after switching-off of the external field. The effect is stipulated by the inertial properties of the electron-hole plasma, possibility of an experimental observation of this effect is discussed too.

## References

- [1] S. M. Schmidt, D. Blaschke, G. Röpke, S.A. Smolyansky, A.V. Prozorkevich and V.D. Toneev, *Int. J. Mod. Phys. E* **7**, 709 (1998).
- [2] B. Dóra and R. Moessner, *Phys. Rev. B* **81**, 165431 (2010).

# STUDY OF $^{238}\text{U}(n, \gamma)$ AND $^{nat}\text{U}(n, f)$ REACTION RATES IN SPALLATION NEUTRON FIELDS PRODUCED BY PROTONS, DEUTERONS AND $^{12}\text{C}$ IONS ON THE MASSIVE URANIUM TARGET QUINTA

V. Sotnikov<sup>1†</sup>, J. Adam<sup>2</sup>, A. Baldin<sup>2</sup>, M. Baznat<sup>3</sup>, S. Chigrinov<sup>3</sup>, V. Chilap<sup>4</sup>,  
W. Furman<sup>2</sup>, K. Gudima<sup>3</sup>, K. Husak<sup>5</sup>, S. Tyutyunnikov<sup>2</sup>, A. Solnyshkin<sup>2</sup>, V. Voronko<sup>1</sup>,  
A. Zhadan<sup>1</sup>, P. Zhivkov<sup>6</sup> and I. Zhuk<sup>5</sup>

(1) NSC Kharkov Institute of Physics and Technology, Ukraine

(2) Joint Institute for Nuclear Research, Dubna, Russia

(3) Institute of Applied Physics, Academy of Sciences of Moldova

(4) Center of Physic and Technical Projects Atomenergomash, Moscow, Russia

(5) The joint institute for power and nuclear research SOSNY, NAS Belarus, Minsk

(6) Institute of Nuclear research and Nuclear Investigations, Bulgaria AS, Sofia

† E-mail: sotnik@kipt.kharkov.ua

The results of the experiments carried out in 2011-2015 within the framework of "Energy and Transmutation of RAW" at JINR NUCLOTRON and Phasotron accelerators are presented. The target assembly QUINTA consisting of natural uranium mass of 512 kg was irradiated by deuteron, carbon and proton beams with energies 1, 2, 4, 6 and 8 GeV (deuterons), 24 and 48 GeV (carbon) and 660 MeV (protons). Spatial distribution of capture reaction  $^{238}\text{U}(n, \gamma)$  and  $^{nat}\text{U}$  fission reaction rates, as well as the integral numbers of capture and fission reactions in the volume of uranium target, was obtained using the activation technique. Figure 1 shows the results of integral numbers of studied reactions per one incident particle and per 1 GeV of beam energy.

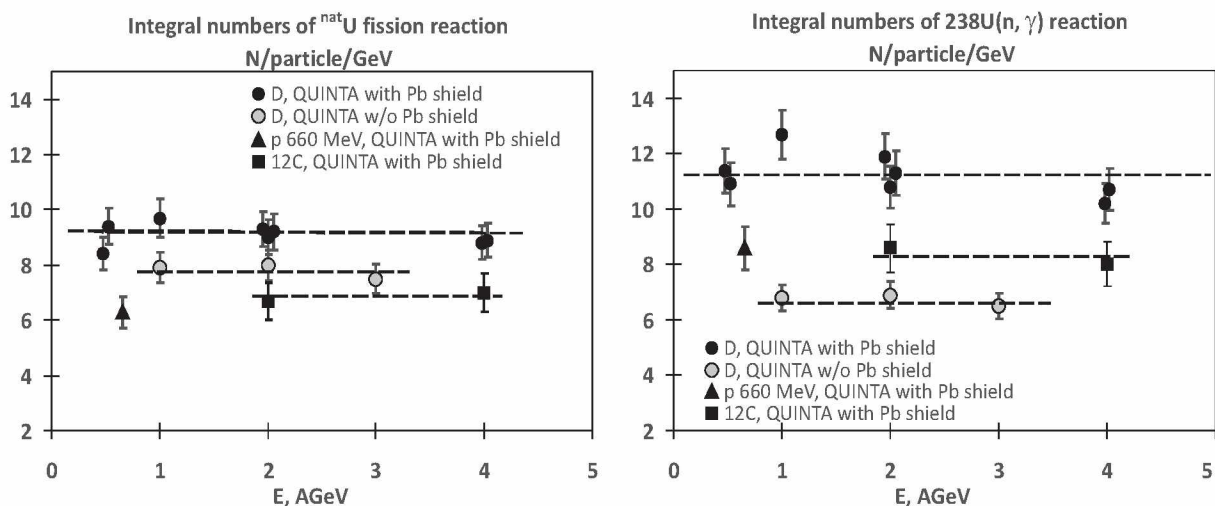

Figure 1: Integral numbers of fissions and capture reactions in the volume of uranium target QUINTA irradiated by deuteron, carbon and proton beams. Experimental data of reaction rates interpolation

The obtained experimental data was analyzed using the MCNPX and SHIELD transport codes.

For example, a comparison of experimental and direct calculated (SHIELD code) integral values of fission and capture for deuteron beams with 2, 4, 8 GeV energy are shown in Figure 2.

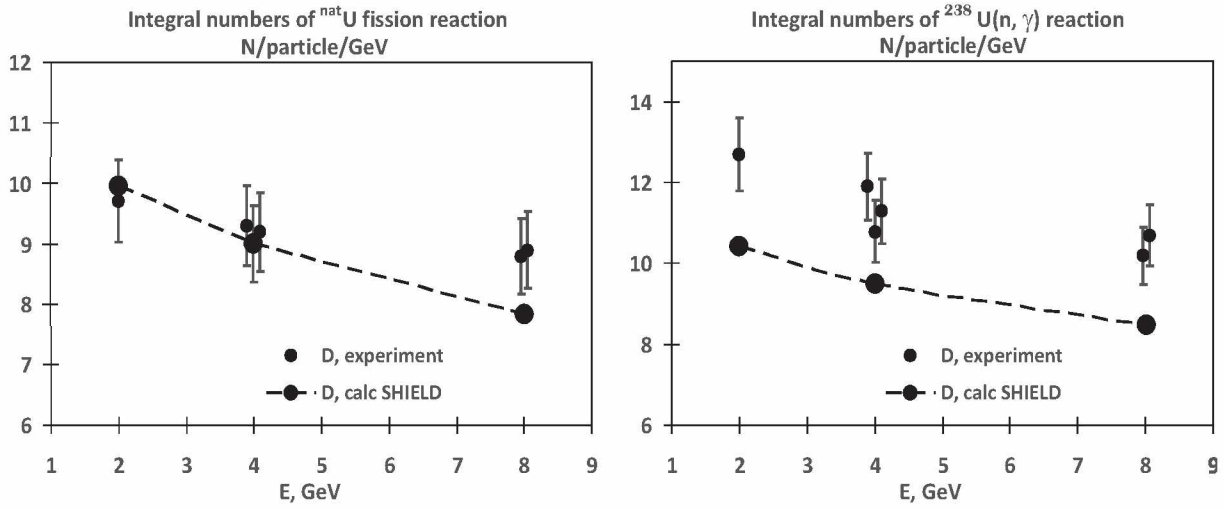

Figure 2: Comparison of experimental and calculated with SHIELD code fission and capture integral values

## AVERAGE FAST NEUTRON FLUX IN THREE ENERGY RANGES IN THE QUINTA ASSEMBLY IRRADIATED BY TWO TYPES OF BEAMS

E. Strugalska-Gola<sup>1</sup>, M. Bielewicz<sup>1,2</sup>, S. Kilim<sup>1</sup>, M. Szuta<sup>1</sup>, A. Wojciechowski<sup>1,2</sup>,  
S. Tyutyunnikov<sup>2</sup>

1. National Centre for Nuclear Research, 05-400 Otwock-Świerk, Poland
2. Joint Institute for Nuclear Research, 141980 Dubna, Russia  
[elzbieta.strugalska-gola@ncbj.gov.pl](mailto:elzbieta.strugalska-gola@ncbj.gov.pl), [marcin.bielewicz@ncbj.gov.pl](mailto:marcin.bielewicz@ncbj.gov.pl)

This work was done within the international project „Energy plus Transmutation of Radioactive Wastes“ (E+T – RAW) for investigations of energy production and transmutation for radioactive waste of atomic energetic.

Yttrium 89 samples were located in the QUINTA assembly in order to measurement of average high neutron flux density in three different energy ranges using deuteron and proton beams in various experiments. Our analysis have shown that both for protons of 0.66 GeV and deuterons of energy 2GeV the neutron density flux for the range of neutron energy 20.8 - 32.7 MeV is higher than for the range of neutron energy 11.5 – 20.8 MeV, while for the deuteron beams of 4 and 6 GeV we do not observe this.



## MONTE CARLO SIMULATIONS OF YTTRIUM REACTION RATES IN QUINTA URANIUM TARGET

M. Suchopár<sup>1,2</sup>, V. Wagner<sup>1,2</sup>, O. Svoboda<sup>1</sup>, J. Vrzalová<sup>1,2,4</sup>, P. Chudoba<sup>1,3</sup>, A. Kugler<sup>1</sup>, J. Adam<sup>1,4</sup>, L. Závorka<sup>2,4</sup>, A. Baldin<sup>4,5</sup>, W. Furman<sup>4</sup>, M. Kadykov<sup>4,+</sup>, J. Khushvaktov<sup>4</sup>, A. Solnyshkin<sup>4</sup>, V. Tsoupko-Sitnikov<sup>4</sup>, S. Tyutyunnikov<sup>4</sup>, M. Bielewicz<sup>6</sup>, S. Kilim<sup>6</sup>, E. Strugalska-Gola<sup>6</sup>, M. Szuta<sup>6</sup>

for the collaboration “Energy and Transmutation of Radioactive Waste”

<sup>1</sup> Nuclear Physics Institute of the ASCR PRI, Hlavní 130, 250 68 Řež, Czech Republic

<sup>2</sup> Faculty of Nuclear Sciences and Physical Engineering, Czech Technical University in Prague, Břehová 7, 115 19 Prague 1, Czech Republic

<sup>3</sup> Faculty of Mathematics and Physics, Charles University in Prague, Ke Karlovu 3, 121 16 Prague 2, Czech Republic

<sup>4</sup> Joint Institute for Nuclear Research, Joliot-Curie 6, 141 980 Dubna, Russia

<sup>5</sup> Institute for Advanced Studies "OMEGA", Universitetskaya 19, 141 980 Dubna, Russia

<sup>6</sup> National Centre for Nuclear Research, 05-400 Otwock-Świerk, Poland

*e-mail: suchopar@ujf.cas.cz*

The international collaboration Energy and Transmutation of Radioactive Waste (E&T RAW) performed intensive studies of several simple accelerator-driven system (ADS) set-ups consisting of lead, uranium and graphite which were irradiated by relativistic proton and deuteron beams in the past years in the Joint Institute for Nuclear Research (JINR) in Dubna, Russia. The most recent set-up called Quinta, consisting of natural uranium target-blanket and lead shielding, was irradiated by deuteron beams in the energy range between 1 and 8 GeV in three accelerator runs at JINR Nuclotron in 2011 and 2012 with yttrium samples among others inserted inside the set-up to measure neutron flux in various places. Suitable activation detectors serve as one of possible tools for monitoring of proton and deuteron beams and for measurements of neutron field distribution in ADS studies. Yttrium is one of such suitable materials for monitoring of high energy neutrons. Various threshold reactions can be observed in yttrium samples. The yields of isotopes produced in the samples were determined using the activation method. Monte Carlo simulations of the reaction rates leading to production of different isotopes were performed in the MCNPX transport code and compared with the experimental results obtained from the yttrium samples.

- [1] M. Suchopar, V. Wagner, J. Vrzalova, O. Svoboda, J. Adam, A.A. Baldin, W.I. Furman, M. Kadykov, A.A. Solnyshkin, V.M. Tsoupko-Sitnikov, S.I. Tyutyunnikov, N. Vladimirovna, L. Závorka and V. Chilap, *Monte-Carlo simulations of natural uranium setups irradiated with relativistic deuterons by means of MCNPX code*, PoS(Baldin ISHEPP XXI)091.
- [2] P. Chudoba, V. Wagner, J. Vrzalova, O. Svoboda, M. Suchopar, M. Majerle, M. Stefanik, A. Kugler, S. Kilim, M.M. Bielewicz, E. Strugalska-Gola and M. Szuta, *Study of cross-sections of yttrium (n,xn) threshold reactions*, PoS(Baldin ISHEPP XXII)054.
- [3] M.M. Bielewicz, S. Kilim, A. Polanski, E. Strugalska-Gola, M. Szuta, A. Wojciechowski, J. Adam, M. Kadykov, V.S. Pronskich, S.I. Tyutyunnikov, V. Wagner, O. Svoboda and V. Chilap, *On results of Y-89 irradiation with deuteron beam on QUINTA-assembly «E+T-RAW» using Nuclotron (JINR Dubna)*, PoS(Baldin ISHEPP XXI)092.
- [4] M.M. Bielewicz, E. Strugalska-Gola, S. Kilim, M. Szuta, S. Tiutiunnikov and W.I. Furman, *Measurements of fast neutron spectrum in QUINTA assembly irradiated with 2, 4 and 8 GeV deuterons*, PoS(Baldin ISHEPP XXII)052.
- [5] M. Szuta, E. Strugalska-Gola, S. Kilim, M.M. Bielewicz, S. Tiutiunnikov and V. Chilap, *Lead shielding impact on fast neutron spectrum (>10MeV) in QUINTA uranium target*, PoS(Baldin ISHEPP XXII)060.



# EFFECT OF THE $\eta\eta$ CHANNEL AND INTERFERENCE PHENOMENA IN THE TWO-PION TRANSITIONS OF CHARMONIA AND BOTTOMONIA

Yu.S. Surovtsev<sup>1†</sup>, P. Bydžovský<sup>(2)</sup>, T. Gutsche<sup>3</sup>, R. Kamiński<sup>(4)</sup>, V.E. Lyubovitskij<sup>(3,5,6)</sup>,  
and M. Nagy<sup>(7)</sup>

(1) *Bogoliubov Laboratory of Theoretical Physics, JINR, 141 980 Dubna, Russia*

(2) *Nuclear Physics Institute of the AS CR, 25068 Řež, Czech Republic*

(3) *Institut für Theoretische Physik, Universität Tübingen, Kepler Center  
for Astro and Particle Physics, Auf der Morgenstelle 14, D-72076 Tübingen, Germany*

(4) *Institute of Nuclear Physics of the PAN, Cracow 31342, Poland*

(5) *Department of Physics, Tomsk State University, 634050 Tomsk, Russia*

(6) *Mathematical Physics Department, Tomsk Polytechnic University,  
Lenin ave. 30, 634050 Tomsk, Russia*

(7) *Institute of Physics of the SAS, Bratislava 84511, Slovak Republic*

† *E-mail: surovcev@theor.jinr.ru*

There is presented a unified analysis of all available data (from the Argus, Crystal Ball, CLEO, CUSB, DM2, Mark II, Mark III, and BES II Collaborations) on the decays of bottomonia  $\Upsilon(mS) \rightarrow \Upsilon(nS)\pi\pi$  ( $m > n$ ,  $m = 2, 3, 4, 5$ ,  $n = 1, 2, 3$ ) and charmonia  $J/\psi \rightarrow \phi\pi\pi$ ,  $\psi(2S) \rightarrow J/\psi\pi\pi$  and of the data on isoscalar  $S$ -wave processes  $\pi\pi \rightarrow \pi\pi, K\bar{K}, \eta\eta$ . The multi-channel  $\pi\pi$  scattering is described in our model-independent approach based on analyticity and unitarity and using an uniformization procedure. The decays of quarkonia are considered assuming that the dipion is produced in the  $S$  wave whereas the final vector meson ( $\phi, \psi, \Upsilon$ ) is a spectator.

It is shown that the basic shape of dipion mass distributions in the two-pion transitions of both charmonia and bottomonia states are explained by an unified mechanism based on the contribution of the  $\pi\pi, K\bar{K}$  and  $\eta\eta$  coupled channels including their interference. The role of the individual  $f_0$  resonances in contributing to the dipion mass distributions in indicated decays of these states is considered.

It is shown that the experimentally observed interesting (even mysterious) behavior of the  $\pi\pi$  spectra of the  $\Upsilon$ -family decays, beginning from the second radial excitation and higher, — a bell-shaped form in the near- $\pi\pi$ -threshold region, smooth dips about 0.6 GeV in the  $\Upsilon(4S, 5S) \rightarrow \Upsilon(1S)\pi^+\pi^-$ , about 0.45 GeV in the  $\Upsilon(4S, 5S) \rightarrow \Upsilon(2S)\pi^+\pi^-$ , and about 0.7 GeV in the  $\Upsilon(3S) \rightarrow \Upsilon(1S)(\pi^+\pi^-, \pi^0\pi^0)$ , and also sharp dips about 1 GeV in the  $\Upsilon(4S, 5S) \rightarrow \Upsilon(1S)\pi^+\pi^-$  — is explained by the interference between the  $\pi\pi$  scattering,  $K\bar{K} \rightarrow \pi\pi$  and  $\eta\eta \rightarrow \pi\pi$  contributions to the final states of these decays (by the constructive one in the near- $\pi\pi$ -threshold region and by the destructive one in the dip regions).

Obviously, the results of the analysis confirm convincingly all of our earlier conclusions on the scalar mesons, which were obtained in the analyses of processes  $\pi\pi \rightarrow \pi\pi, K\bar{K}, \eta\eta$  [1,2].

## References

- [1] Yu.S. Surovtsev, P. Bydžovský, V.E. Lyubovitskij, R. Kamiński, and M. Nagy, *Masses and widths of scalar-isoscalar multi-channel resonances from data analysis*, J. Phys. G: Nucl. Part. Phys. **41** (2014) 025006.
- [2] Yu.S. Surovtsev, P. Bydžovský, V.E. Lyubovitskij, R. Kamiński, and M. Nagy, *Parameters of scalar resonances from the combined analysis of data on processes  $\pi\pi \rightarrow \pi\pi, K\bar{K}, \eta\eta$  and  $J/\psi$  decays*, Phys. Rev. D **89** (2014) 036010.
- [3] Yu.S. Surovtsev, P. Bydžovský, T. Gutsche, R. Kamiński, V.E. Lyubovitskij, and M. Nagy, *Role of multichannel  $\pi\pi$  scattering in decays of bottomia*, Phys. Rev. D **91** (2015) 037901; arXiv:1502.05368[hep-ph].
- [4] Yu.S. Surovtsev, P. Bydžovský, T. Gutsche, R. Kamiński, V.E. Lyubovitskij, and M. Nagy, *Unified description of BaBar and Belle data on the bottomonia decays  $\Upsilon(mS) \rightarrow \Upsilon(ns)\pi^+\pi^-$* , Phys. Rev. D **92**, 036002 (2015); arXiv:1506.03023[hep-ph].

# LAMBDA POLARIZATION FEASIBILITY STUDY AT BM@N

D. Suvarieva<sup>1,2†</sup>, K. Gudima<sup>2</sup> and A. Zinchenko<sup>2</sup>

(1) *Ploudiv University "Paisii Hilendarski"*

(2) *Joint Institute for Nuclear Research  
Dubna, Moscow region, Russia, Bulgaria*

† *E-mail: DilyanaSuvarieva@mail.bg*

Heavy strange objects (hyperons) could provide essential signatures of the excited and compressed baryonic matter. At NICA, it is planned to study hyperons both in the collider mode (MPD detector) and the fixed-target one (BM@N setup).

The parity-preserving polarization of strange hyperons in hadronic interactions is transverse to scattering plane. It is large and sensitive to the strong interactions mechanisms. In the heavy-ion collisions this polarization can be diluted, while the polarization transverse to reaction plane may emerge. It is sensitive to parity-odd characteristics of QCD medium (vorticity, hydrodynamic helicity) and to QCD anomalous transport.

In this analysis, the possibility to measure at BM@N the polarization of the lightest strange hyperon  $\Lambda$  is studied in Monte Carlo event samples produced with the DCM-QGSM generator. The  $\Lambda$  decay to proton and negative pion is fully reconstructible and the polarization can be extracted from the angular distribution of the final state particles.

It is shown that the detector will allow to measure  $\Lambda$  polarization with a precision required to check the model predictions.

# COMPARISON OF TWO FAST NEUTRON MEASUREMENT METHODS BASED ON Np-237 FISSION TO CAPTURE RATIO MEASUREMENT (SPECTRAL INDEX) AND A REVERSE DARK CURRENT MEASUREMENT OF PLANAR SILICON DETECTOR

M. Szuta<sup>1</sup>, S. Kilim<sup>1</sup>, E. Strugalska-Gola<sup>1</sup>, M. Bielewicz<sup>1,2</sup>, N.I. Zamyatin<sup>2</sup>, A. Shafronovskaia<sup>2</sup>, S. Tyutyunnikov<sup>2</sup>

1. National Centre for Nuclear Research, 05-400 Otwock-Świerk, Poland
2. Joint Institute for Nuclear Research, 141980 Dubna, Russia

It is a subsequent step of feasibility study of fast neutron fluency measurement using two different complementary methods.

The idea of the first method is to search the neutron energy for the ratio of fission cross section to capture cross section of the selected actinide isotope from the nuclear data base that is equal to the measured ratio of fissioned and captured actinide isotope Np-237.

The idea of the second method is measurement of fast neutron irradiation induced reverse dark current increase of planar silicon detectors which is linearly proportional to neutron fluence.

Np-237 samples and planar silicon detectors were placed inside a subcritical assembly (the Quinta assembly at the Joint Institute for Nuclear Research, Russia) very close to each other assuming that in both samples (detectors) the same neutron fluence shall pass.

The assembly was irradiated by pulsed proton and deuteron beams (the proton energy was 0.66 GeV and the deuteron energy was 2, 4 and 8 GeV). After the irradiation, gamma-rays of <sup>133</sup>I, <sup>97</sup>Zr, <sup>135</sup>I, and <sup>238</sup>Np from the actinide samples were measured for evaluating the fission/capture rates of <sup>237</sup>Np and the reverse dark current of silicon detector was measured in order to estimate the fast neutron fluence and compare the results of both methods.

In the research, the fluence were estimated to be about  $10^{13}$  n/cm<sup>2</sup> in the case of proton irradiation and about  $10^{12}$  n/cm<sup>2</sup> in the case of deuteron irradiation. In both cases the fluence measured by silicon detectors method was regularly (systematically) about 35% less than the fluency estimated by actinide methods. This could be expected because the silicon detector method effectively measure the fast neutrons of energy higher than 100 keV, while the Np-237 detectors (samples) measure the neutron fluence in the whole energy range. So the difference of two fast neutron fluence measurements gives estimation of neutron fluence for the neutron energy below 100 keV – the additional approach.

It is concluded that minor actinide samples and planar silicon detectors can be used as neutron fluence detectors especially in the high neutron energy range that is difficult to measure.

Given the importance of high energy neutron measurement in the ADS (Accelerator Driven System) the actinide and silicon detectors could be a very useful tool.

# STOCHASTIC NONLINEAR EQUATION OF QUARK-GLUON CASCADE

A.T. Temiraliev , I.A. Lebedev

*Institute of Physics and Technology, Almaty, Kazakhstan*

Consideration of the contribution to the quark-gluon distribution of bremsstrahlung of gluons leads to a violation of Bjorken's scaling and is determined by known linear evolution equations: Dokshitzer-Gribov-Lipatov-Altarelli-Parisi (DGLAP), Balitsky-Fadin-Kuraev-Lipatov (BFKL) and Gribov-Levin-Ryskin-Mueller-Qiu (GLR-MQ). Proposed many ways to the modeling of evolution equations with non-perturbative nonlinearities, considering the gluon recombination. In addition to the gluon splitting functions, the nonlinear gluon recombination processes become important.

Considering the evolution as a discrete quantum process we use the mathematical apparatus of discrete mappings within the framework of nonlinear dynamics theory. In the spirit of Feynman's path integrals we propose a nonlinear stochastic equation in the form of the evolution of nucleon structure function  $F_2(x, Q^2)$ , which represents the evolution nonlinear operator for one time step showing the momentum distribution on the momentum in the momentum representation. Using the method of Poincare sections (choosing the share of momentum as a one-dimensional section of the phase space of partons momentum distribution) we have an evolution equation:  $x_{t+1} = \hat{F}(x_t, R)$ . Here Bjorken's/Feynman's variable  $x_t$  is the momentum fraction at discrete time index ( $t=0, 1, 2, \dots$ ) and  $R$  is the control parameter that characterizes the degree of coupling embossed parton with the totality of the remaining partons in the nucleon at the certain energy  $\sqrt{s}$  and determines the character of observing regimes. To switch to continuous time allows the build, known as the Poincare section. In the framework of our quality approach we use the renormalization-group approach to the evolution equation, allowing to recreate a physical picture of the critical behavior.

So for the quark-gluon cascade, we enter an iterative map in which a number of the quarks and gluons in  $(t+1)$ -th generation are proportional to the number of them in  $t$ -th generation. The number of partons are changing, but remains on total momenta. Thus, the probability to find a parton with a fraction of momentum  $x$  at time  $t+1$  is defined by the impulse distribution of partons in the time  $t$ .

Positive terms of hadron structure function meet the increasing of the quarks ( $q$ ) and gluons ( $g$ ) number at cascade:  $q \rightarrow q+g$  and  $g \rightarrow g+g$  and negative terms is the reduction, i.e. quark-antiquark, quark-gluon and gluon-gluon recombination.

Using the method of Poincare sections (choosing the share of momentum as a one-dimensional section of the phase space of partons momentum distribution) and considering that the evolution operator is determined by hadron structure functions ( $F_2$ ), we use a one-dimensional map.

Numerical solution of the nonlinear equation has shown the existence of an evolution termination in the field of small values of parameter. Small perturbations do not change the Q-G condition ( $R \ll 1$ ). The increase in  $R$  leads at first only to the excitation stable state. With further increase of the parameter occur repeated bifurcation (splitting) of period-doubling. calculations of the quarks phase trajectories have shown the presence of the chaotic dynamics at  $R \gg 0$  as a consequence of bifurcations. In a state of dynamic chaos two close orbits in phase space diverge exponentially with time with Lyapunov's coefficient in the exponent,

which in a computer simulation, is calculated using parallel running of two close initial conditions and examines their divergence. By computer simulation the studies of the formation of stable structures in quark-gluon cascade, including recombination processes.

The nature of stability of fixed points (cycles) and the type of bifurcations of mappings are determined by their multipliers. In turn, multipliers are the own numbers of the Jacobian matrix perturbations. The maximum value  $x_{t+1}$  is found from  $dx_{t+1}/dx_t=0$ . The Jacobian is

$$J = \left| \frac{dx_{t+1}}{dx_t} \right| \quad \text{and the map is stable at a point } x_0 \text{ if } J(x_0) < 1. \text{ When the coupling constant } \alpha_s(Q^2)$$

is small, the evolution is incoherent, if the relationship is strong enough that can occur spontaneous synchronization quark-gluon movements.

Dynamic quark-gluon systems are highly sensitive to the initial conditions. There are nonperturbative effects associated with initial transverse momenta of partons inside the hadron and there are always fatal even quantum zero fluctuations. It is possible that a steady structure formation in nonlinear quark-gluon evolution is a mechanism of hadronization. Arising in the quark-gluon cascade the strange attractor with a fractal self-similar structure display a new nonlinear phenomenon in the hadron physics is deterministic chaotic dynamics.

**THE DIFFERENTIAL CROSS SECTION FOR dp-ELASTIC  
SCATTERING AT 500-900 MeV/n**

A.A. Terekhin<sup>1†</sup>, S.M.Piyadin<sup>1</sup>, V.P.Ladygin<sup>1</sup>, A.N.Khrenov<sup>1</sup>, A.Yu.Isupov<sup>1</sup>,  
Yu.V.Gurchin<sup>1</sup>, A.K.Kurilkin<sup>1</sup>, P.K.Kurilkin<sup>1</sup>, S.G.Reznikov<sup>1</sup>, I.E.Vnukov<sup>2</sup>.

(1) *JINR, 141980, Dubna, Moscow region, Russia*

(2) *BelSU, 308015, Belgorod, Russia*

† *E-mail: aterekhin@jinr.ru*

The results of the differential cross section measurements of dp-elastic scattering at energies from 500 to 900 MeV/nucleon at Nuclotron JINR are reported. The data were obtained for angles range of 70-120° in the c.m.s. The results are compared with existing world data.

## HYPERONS POLARIZATION IN HEAVY-ION COLLISIONS

M. Baznat<sup>1,2</sup>, K.Gudima<sup>2</sup>, A.S. Sorin<sup>1,3</sup>, O.V. Teryaev<sup>1,3</sup>

1. *Joint Institute for Nuclear Research, 141980 Dubna, Moscow region, Russia*
2. *Institute of Applied Physics, Academy of Sciences of Moldova, MD-2028 Kishinev, Moldova*
3. *Dubna International University, 141980 Dubna, Moscow region, Russia*

Different mechanisms of generation of hyperon polarization in heavy-ion collisions are discussed and compared. The anomalous mechanism suggested earlier [1] is realized in the framework of kinetic (QGSM) model. The prediction of energy dependence [1] confirmed by STAR collaboration is quantified and studied in some detail.

### REFERENCES

1. O. Rogachevsky, A. Sorin and O. Teryaev // *Phys. Rev. C* - 2010.- V.82.-P. 054910



## IRRADIATION OF QUINTA ASSEMBLY BY 660 MEV PROTON BEAM AND 4 GEV AND 8 GEV DEUTERON BEAMS

P. Tichy<sup>1,2,3</sup>, M. Suchopar<sup>2,3</sup>, L. Zavorka<sup>1,3</sup>, J. Adam<sup>1</sup>, V. Wagner<sup>2</sup>, J. Vrzalova<sup>1,2,3</sup>, R. Vespalec<sup>1,3</sup>, M. Zeman<sup>1,4</sup>, A. A. Solnyshkin<sup>1</sup>, J. Khushvaktov<sup>1</sup>, J. Svoboda<sup>1,4</sup>, Yu. Kish<sup>1,5</sup>, P. Chudoba<sup>2,6</sup>

1. *Joint Institute for Nuclear Research, Dubna, Russia*
2. *Nuclear Physics Institute, Czech Academy of Sciences, Rez, Czech Republic*
3. *Czech Technical University, Prague, Czech Republic*
4. *Brno University of Technology, Brno, Czech Republic*
5. *Uzhgorod National University, Uzhgorod, Ukraine*
6. *Charles University, Prague, Czech Republic*

Collaboration “Energy&Transmutation of Radioactive Waste” is involved in experiments with subcritical transmutation setups. It is important for development of accelerator driven systems (ADS) and fast nuclear reactors. The setups are made from lead or uranium target which is surrounded by natural or depleted uranium blanket. High energy proton or deuteron beam from Phasotron or Nuclotron accelerator is aimed to the target and neutrons are produced by spallation reactions. These neutrons are suddenly multiplied in the subcritical blanket and huge neutron fields are created inside the setup.

Experimental assembly QUINTA was irradiated in November 2013 by 4 GeV deuteron beam, in December 2013 by 8 GeV deuteron beam on Nuclotron accelerator and in November 2015 by 660 MeV proton beam on Phasotron accelerator in the Joint Institute for Nuclear Research. Activation samples of <sup>59</sup>Co, <sup>27</sup>Al and <sup>nat</sup>Pb were placed inside the QUINTA in various positions during the experiments. Reaction rates (neutron flux) of <sup>57</sup>Co, <sup>58</sup>Co, <sup>24</sup>Na, <sup>205</sup>Bi and <sup>206</sup>Bi production were evaluated by activation techniques. Experimental results were then compared with Monte Carlo simulations.

## RECENT STAR HEAVY-ION RESULTS

M.V. Tokarev  
(for the STAR Collaboration)

*Joint Institute for Nuclear Research, Dubna, Russia*  
*E-mail: tokarev@jinr.ru*

The main goal of physics program at the Relativistic Heavy Ion Collider is to produce a new state of the nuclear matter in collisions of heavy ions and to investigate its properties over a wide range of energy, centrality with various probes. Experiments with nuclei performed at RHIC have provided evidence that a new state of the nuclear matter exists. This new state is characterized by a suppression of particle production at high  $p_T$ , a large amount of elliptic flow ( $v_2$ ), constituent quark number scaling of  $v_2$  at intermediate  $p_T$  and enhanced correlated yields at large  $\Delta\eta$  and  $\Delta\phi \simeq 0$  (the ridge effect). An important step towards understanding the structure of the the phase diagram of the nuclear matter in the framework of QCD is a systematic analysis of the particle production as a function of a collision energy, centrality and collisions species. Therefore the principal challenge remains localization of phase boundaries and the critical point on the QCD phase diagram. We will present the recent STAR heavy-ion results obtained in the first phase of the RHIC Beam Energy Scan program. The measurements of particle spectra have been performed over a wide range of collision energy  $\sqrt{s_{NN}}=7.7-200$  GeV, centrality and transverse momentum of produced particle. The fixed target mode in heavy-ion collisions at the STAR experiment also extends considerably the range of search for the new physics. Heavy quarks provide an exceptional probe in understanding properties of the hot and dense medium created in such collisions. The Heavy Flavor Tracker (HFT) and Muon Telescope Detector (MTD) upgrades at the STAR experiment at RHIC significantly improved the experimental capabilities of TPC, ToF and EMC detectors in measuring both open and hidden heavy flavor hadrons in heavy-ion collisions.

# HIGHLIGHTS IN HADRON ELECTROMAGNETIC STRUCTURE

Egle Tomasi-Gustafsson<sup>1†</sup>, Andrea Bianconi<sup>2</sup> and Simone Pacetti<sup>3</sup>

(1) *IRFU, CEA, Université Paris-Saclay, 91191 Gif-sur-Yvette Cedex, France*

(2) *Dipartimento di Ingegneria dell'Informazione, Università di Brescia  
and Istituto Nazionale di Fisica Nucleare, via A. Bassi 6, 27100 Pavia, Italy*

(3) *Dipartimento di Fisica e Geologia, and INFN Sezione di Perugia, 06123 Perugia, Italy*

† *E-mail: egle.tomasi@cea.fr*

In this contribution the discrepancy between unpolarized and polarized extraction of the proton electromagnetic form factor is critically revised, in particular the historical roots of the commonly used dipole parametrization. A recent reanalysis of Rosenbluth data in electron proton elastic scattering in terms of form factor ratio, shows agreement between the value of this ratio whenever extracted from polarized or unpolarized experiments. In particular the large sensitivity of the ratio to radiative corrections and normalization of the cross section may solve the discrepancy in frame of the one photon exchange mechanism [1].

The analytical properties of form factors suggest a common interpretation in scattering and annihilation experiments. Recent precise ISR data on electron-positron annihilation into a proton antiproton pair show oscillations in the  $s$ -dependence of the cross section. Extracting the proton form factors and plotting these data as a function of the 3-momentum of the relative motion of the final proton and antiproton, a systematic sinusoidal modulation appears in the near-threshold region, typical of an interference pattern. Through a Fourier analysis, the period is shown to correspond to a relative distance of 0.7-1.5 fm between the centers of the forming hadrons. It has been suggested that a rescattering process at the level of the newly formed hadrons interferes with the processes at a much smaller scale driven by the quark dynamics [2]. These oscillations may be interpreted a signature of early mechanism of hadron creation.

## References

- [1] S. Pacetti and E. Tomasi-Gustafsson, arXiv:1604.02421 [nucl-th].
- [2] A. Bianconi and E. Tomasi-Gustafsson, Phys. Rev. Lett. **114**, 232301 (2015), Phys. Rev. C **93**, 035201 (2016).

# MINKOWSKI SPACE APPROACH FOR THE BETHE-SALPETER EQUATION

L. Tomio<sup>1,2†</sup>

(1) *Instituto Tecnológico de Aeronáutica, DCTA, 12.228-900 So José dos Campos, SP, Brazil*

(2) *Instituto de Física Teórica, UNESP, 01156-970 São Paulo, SP, Brazil*

† *E-mail: tomio@ift.unesp.br*

I am reporting a study on the Nakanishi Integral Representation (NIR) of the Bethe-Salpeter (BS) amplitude, which was performed in Refs. [1]-[3]. The NIR was previously devised in the perturbative regime, being extended to the non-perturbative regime, where it was applied to obtain bound-state solutions of the BS equation in 2+1 and 3+1 dimensions. In the case of 2+1 dimensions, the model is not applicable to real systems [2]. However, we consider it in view of promising applications in condensed matter physics, as well as to face the main difficulties for implementing the NIR of the BS formalism. The approach, restricted to the Yukawa model of two spinless massive bosons interacting by means of another scalar boson, enables to solve the Bethe-Salpeter equation directly in Minkowski space, instead of the usual calculation performed in the Euclidean space. The quantitative investigation was done in the ladder-approximation framework, first by confirming the reliability of the method when applied to the ground state, and next by extending the approach to excited states. The equivalence of the results obtained in Minkowski and Euclidean spaces was verified for the eigenvalues, as well as for the transverse-momentum amplitudes.

## References

- [1] C. Gutierrez, V. Gigante, T. Frederico, G. Salmé, M. Viviani, L. Tomio, Phys. Lett. B **759**, 131-137 (2016).
- [2] V. Gigante, T. Frederico, C. Gutierrez, L. tomio, Few-Body Syst. **56**, 375-380 (2015).
- [3] C. Gutierrez, PhD thesis, Instituto de Física Teórica, in preparation (2016).

## HEAVY ION COLLISIONS IN A FIXED TARGET MODE AT THE LHC BEAMS

A.B. Kurepin and N.S. Topilskaya

*Institute for Nuclear Research, RAS*

E-mail: [kurepin@inr.ru](mailto:kurepin@inr.ru), [topilska@inr.ru](mailto:topilska@inr.ru)

The collisions of the high energy LHC beams with fixed target, including polarized nuclei targets, can expand the range of fundamental physical investigations accessible at CERN. High-intensity beams of protons and lead ions accumulated in the LHC collider, allows the use of the beam halo, by placing in the halo the fixed target or a curved crystal to extract the beam. Also in the extracted beam is possible to install a polarized target. Using the proton and ion beams at the LHC with fixed targets, the data in the energy interval between maximum energy of the SPS and the nominal RHIC energy in p-A and A-A collisions could be obtained. The fixed target mode allows for an intensive study of rare processes, the study of polarization phenomena, the measurements of the parameters needed to analyze the data of cosmic rays and neutrino astrophysics, detailed study of the processes of quarkonia production and suppression. The high statistics data on quarkonium production at these energies will give the possibility to clarify the mechanism of quarkonium production, to investigate the importance of recombination process and the energy dependence on the phase transition of matter to quark-gluon phase. Also the physical program includes the Drell-Yan measuring, the study of D-meson production, flow and spin physics.

## CHARGE STRUCTURE OF $\Lambda$ -HYPERON

S.V. Trubnikov

Kharkov National Karazin University, Kharkov, Ukraine

E-mail: [sergiy.v.trubnikov@gmail.com](mailto:sergiy.v.trubnikov@gmail.com)

Lambda hyperon  $\Lambda$  (1115) is the second neutral baryon and the first baryon which contains strange quark, so its structure is (with other strange particles) the useful source of information for the quark dynamics in hadrons. Among several questions it is also interesting to make it clear the sign (and value) of the mean-square charge radius of  $\Lambda$ -hyperon  $\langle r_\Lambda^2 \rangle$ : does it reproduce the neutron's phenomenon ( $\langle r_n^2 \rangle < 0$ ) or not?

In the present paper the value of  $\langle r_\Lambda^2 \rangle$  is calculated in different variants of relativistic quark and hadron models. The comparison with the results of other authors is also made. The results are somewhat contradictory:  $\langle r_\Lambda^2 \rangle$  may be both positive ( $0,02 fm^2 \div 0,12 fm^2$ ) and negative ( $-0,11 fm^2 \div -0,03 fm^2$ ). So the new experimental measurements of  $\langle r_\Lambda^2 \rangle$  are quite desirable. In principle we offer to try to do it in the experiment on electroproduction of  $\Lambda, K^+$  - pair on proton target  $p(e, e' \Lambda) K^+$  in such a kinematic when the 3-momentum of final kaon approximately equals to zero ( $p(K^+) \approx 0$ ). In this case in the framework of existing theoretical models it's possible to extract the  $\Lambda$  charge form factor for low values of four-momentum transfer squared  $Q^2$  and then calculate  $\langle r_\Lambda^2 \rangle$ .

To investigate the electromagnetic structure of  $\Lambda$ -hyperon for higher  $Q^2$  it's natural to use the intensive secondary beam of  $\Lambda$ -hyperons in its scattering on the atomic electrons. Really, for the reaction

$\Lambda + e^- \rightarrow \Lambda + e^-$  the  $Q^2$  is equals to  $(-q_\mu)^2 \equiv Q^2 = 4m_e^2 \frac{p \cdot \cos^2 \Theta}{(E + m_e)^2 - p^2 \cdot \cos^2 \Theta}$  where  $E, p$  are the energy and 3-momentum of  $\Lambda$ -hyperon and  $\Theta$  is the angle between the vectors  $\vec{p}$  and  $\vec{p}^e$ . For example, in the range  $E = 500 Gev - 1 Tev$  the maximal (for forward scattering  $\Theta \rightarrow 0$ )  $Q^2$  interval due to damping factor  $m_e^2$  is not very large:  $12.5 fm^{-2} \leq Q^2 \leq 25 fm^{-2}$ . Naturally, the energy of knocked out electron is very high:

$$E'_e = m_e \times \frac{(E + m_e)^2 + (p \cos \Theta)^2}{(E + m_e)^2 - (p \cos \Theta)^2}$$

This energy is maximal in  $\vec{p}$ -direction:  $(E'_e)_{\max} = E + m_e \approx E = 500 Gev - 1 Tev$ . The recoil electrons of such high energy may be with large efficiency shared out by the transitional radiation detectors.

# SEARCH FOR T-INVARIANCE VIOLATION IN PD-SCATTERING

Yu.N. Uzikov<sup>1†</sup>

(1) *Joint Institute for Nuclear Research, Dubna, Russia*

† *E-mail: uzikov@jinr.ru*

The discrete symmetries of parity (P) and time reversal (T) play a crucial role in our understanding of fundamental interactions. CP-violation (or T-violation assuming CPT symmetry, where C stands for charge conjugation) is required to account for the baryon asymmetry of the universe. Since within the standard model the CP-violation observed in physics of kaons and  $B$ -mesons is by far not sufficient to explain this asymmetry, other sources of CP-violation have to be found.

Scattering of protons with transversal polarization  $p_y^p$  on deuterons with tensor polarization  $P_{xz}$  provides a null-test signal for time-reversal invariance violating but P-parity conserving effects. The dedicated experiment will be done at COSY [1] at proton beam energies 135 MeV [3] using internal deuteron target. I will give a brief review of results of our calculations [4, 5, 6, 7, 8, 9] of the corresponding null-test observable at beam energies 100–1000 MeV within the spin-dependent Glauber theory [2] considering T-violating P-conserving nucleon-nucleon interactions. The  $S$ -wave component of the deuteron wave function as well as the  $D$ -wave are taken into account and the latter is found to play an important role for the magnitude and the energy dependence of the observable in question. Specifically, with inclusion of the  $D$  wave the maximum of the expected signal is shifted to higher beam energies, i.e. to 700 – 800 MeV [9].

## References

- [1] P.D. Eversheim, B. Lorentz, Yu. Valdau et al., COSY Proposal, N 215 (2012).
- [2] M.N. Platonova, V.I. Kukulín, Phys. Rev. **C81**, 014004 (2010).
- [3] M. Beyer, Nucl. Phys. **A560**, 895 (1993).
- [4] A.A. Temerbayev, Yu.N. Uzikov, Yad. Fiz. **78**, 38 (2015).
- [5] Yu.N. Uzikov, A.A. Temerbayev, Phys. Rev. C **92**, 014002 (2015).
- [6] A.A. Temerbayev, Yu. N. Uzikov, Izv. Ross. Akad. Nauk Ser. Fiz. **80**, 271 (2016)
- [7] Yu.N. Uzikov, Jour. Phys.: Conf. Ser. **678**, 012020 (2016).
- [8] Yu.N. Uzikov, Eur. Phys. J. Web of Conf. **113**, 04027 (2016).
- [9] Yu.N. Uzikov, J.Haidenbauer, arXiv:1607.04409 [nucl-th].

# LONG-RANGE RAPIDITY CORRELATIONS BETWEEN MEAN TRANSVERSE MOMENTA

V.V. Vechernin<sup>†</sup>

*Saint-Petersburg State University*

<sup>†</sup> *E-mail: v.vechernin@spbu.ru*

It is argued that the investigations of the forward-backward correlations between intensive observables enable to obtain more clear signal on the initial stage of hadronic interaction, e.g. about the process of string fusion [1, 2], compared to usual forward-backward multiplicity correlations [3]. As an example the  $p_t$ - $p_t$  correlation between mean-event transverse momenta of charged particles in separated rapidity intervals is considered [4, 5].

The calculations are fulfilled in the model with string fusion by introducing a lattice in transverse plane. This approach was introduced in [6] and then was successfully exploited for a description of various phenomena in ultra relativistic nuclear collisions [7]-[10].

The dependence of the correlation strength on the collision centrality is obtained for different initial energies. It is shown that in Pb-Pb interactions at LHC this dependence reveals the drop of the correlation coefficient for most central collisions. The model calculations show that the physical reason of this decrease is the attenuation of color field fluctuations due to the string fusion at large string density.

It is significant that this non-monotonic behaviour of the  $p_t$ - $p_t$  correlation coefficient with collision centrality is achieved only at LHC, whereas at RHIC energy the string density is not enough to provide a decline of the correlation coefficient for most central collisions due to the string fusion processes. This conclusion is confirmed by the results [11], obtained in more realistic dipole-based Monte Carlo string fusion model [12, 13].

It is demonstrated also that in contrast to the correlation between transverse momenta of single particles [14] the strength of the correlation between mean-event transverse momenta of particles in two separated rapidity intervals is not decreasing with the total number of produced strings, remaining significant even in the case of Pb-Pb collisions, in which the total number of strings can reach several thousand [5, 15]. The reason of the difference between these two types of  $p_t$ - $p_t$  correlation is that compared to transverse momenta of single particles the mean transverse momenta, being intensive variables, are more sensitive to the value of string tension, as they reflect the specific event transverse energy in observation rapidity windows.

All this makes this type of correlation promising for the observation of the signatures of the string fusion phenomenon at the initial stage of hadronic interaction in relativistic heavy ion collisions at LHC energy.

The work was supported by the RFBR grant 15-02-02097-a and the Saint-Petersburg State University grant 11.38.197.2014.

## References

- [1] M.A. Braun, C. Pajares, Phys. Lett. **B287**, 154 (1992).



- [2] M.A. Braun, C. Pajares, Nucl. Phys. **B390**, 542 (1993).
- [3] N.S. Amelin et al., Phys. Rev. Lett. **73**, 2813 (1994).
- [4] ALICE collaboration et al., J. Phys. **G32**, 1295 (2006), [Sect. 6.5.15].
- [5] V.V. Vechernin, R.S. Kolevatov, Phys. Atom. Nucl. **70**, 1809 (2007).
- [6] V.V. Vechernin, R.S. Kolevatov, Vestn. Peterb. Univ., Ser.4: Fiz. Khim., No.4, 11 (2004), arXiv: hep-ph/0305136.
- [7] M.A. Braun, C. Pajares, Eur. Phys. J. **C71**, 1558 (2011).
- [8] M.A. Braun, C. Pajares, V.V. Vechernin, Nucl. Phys. **A906**, 14 (2013).
- [9] M.A. Braun, C. Pajares, V.V. Vechernin, Eur. Phys. J. **A51**, 44 (2015).
- [10] V.V. Vechernin, Theor. Math. Phys., **184**, 1271 (2015).
- [11] V. Kovalenko, V. Vechernin, EPJ Web of Conferences **66**, 04015 (2014).
- [12] V.N. Kovalenko, Phys. Atom. Nucl. **76**, 1189 (2013).
- [13] V. Kovalenko, V. Vechernin, Proceedings of Science **Baldin-ISHEPP-XXI**, 077 (2012).
- [14] M.A. Braun, R.S. Kolevatov, C. Pajares, V.V. Vechernin, Eur. Phys. J. **C32**, 535 (2004).
- [15] J. Dias de Deus et al., Eur. Phys. J. **C72**, 2123 (2012).

# PROTON AND NEUTRON POLARIMETRY IN THE RANGE 1-6 GeV/c

Y. WANG<sup>1†</sup>, D. Marchand<sup>1</sup>, N.M. Piskunov<sup>2</sup> and E. Tomasi-Gustafsson<sup>3</sup>

(1) *Univ Paris-Sud, CNRS/IN2P3, Institut de Physique Nucléaire, UMR 8608, 91405 Orsay, France*

(2) *Joint Institute for Nuclear Research, VBLHE, 141980 Dubna, Russia*

(3) *CEA,IRFU,SPhN, Saclay, 91191 Gif-sur-Yvette Cedex, France*

† *E-mail: wangying@ipno.in2p3.fr*

Proton polarimetry has been revealed to be a unique way to access the electric to magnetic proton form factor ratio, as the ratio of the GE/GM can be directly measured from the ratio of transverse to longitudinal polarization of the recoil proton in the scattering of linearly polarized electrons. To extract electromagnetic form factors (FFs) for polarized  $eN$  elastic experiment, polarization experiments are needed. Measuring analyzing power of ALPOM2 experiment is the first step to conceive and optimize a polarimeter to measure proton (neutron) polarization.

ALPOM2 experiment [1] will measure the neutron and proton analyzing power of momentum up to  $p_{Lab} = 4.5$  GeV/c and 7.5 GeV/c for the future polarized  $eN$  elastic experiment  $Q^2$  over 10 GeV<sup>2</sup> in JLab. We studied the figure of merit which is the performance of a polarimeter, to optimize the method of the experiment. In the former ALPOM [2], different influences on proton analyzing power have been given. For neutron, based on a pole model [3], predictions of differential cross sections and comparison with data for the reactions of charge-exchange (CE)  $np \rightarrow pn$  and zero-exchange (ZE)  $np \rightarrow pn$  are presented. With the analyzing power of two processes, the figure of merit for neutron indicates that the CE has a better performance after the momentum about 3 GeV/c.

## References

- [1] Spokespersons: N.M. Piskunov, C.F. Pedrisat, V. Punjabi, E. Tomasi-Gustafsson, Measurement of analyzing powers for the reaction  $p + CH_2$  up to 7.5 GeV/c and  $n + CH$  up to 4.5 GeV/c at the Nuclotron, ALPOM2 proposal to JINR Dubna PAC, March (2015).
- [2] L. S. Azhgirei et al., Nucl. Instrum. Meth. A 538, 431 (2005).
- [3] Yu. A. Troyan et al., Elastic  $np \rightarrow np(pn)$  scattering at intermediate energies. Physics of Particles and Nuclei Letters, 11(2):101108, 2014

## **ESTIMATION OF TOLERANCES ON SYNCHROTRON ELEMENTS PARAMETERS FOR BIOMEDICAL RESEARCH**

I.P. Yudin

*Joint Institute for Nuclear Research, Dubna Moscow region, Russia*

The influence of perturbations in magnetic elements of a biomedical synchrotron is studied by means of numerical calculations. At given momentum spread of beam particles the influence of lenses longitudinal alignment errors and allowances for lengths and gradients of quadrupole lenses in matched insertion on maximum of  $\beta$ -function ( $\beta_{\max}$ ) and betatron oscillations frequency is calculated.

# MANIFESTATION OF THE UNSTABLE NUCLEI IN RELATIVISTIC DISSOCIATION OF THE $^{10}\text{B}$ AND $^{11}\text{C}$ NUCLEI

A.A. Zaitsev<sup>1</sup>

## 1. Joint Institute for Nuclear Research

In the framework of the BECQUEREL Project in JINR the nuclear track emulsion (NTE) technique allowed one to investigate clustering of the nuclei Li, Be, B, C and N in their relativistic dissociation. With an unsurpassed spatial resolution (about 0.5  $\mu\text{m}$ ) NTE provides a complete observation of tracks starting from fission fragments and down to relativistic particles. Fragment tracks observed in NTE is a “building blocks” the light nuclei include the lightest clusters having no excited states, namely,  $\alpha$ -particles, tritons,  $^3\text{He}$  nuclei, and deuterons. A pair and triples of protons and  $\alpha$ -particles can constitute the unstable  $^8\text{Be}$  and  $^9\text{B}$ . Analysis of NTE exposed by  $^{11}\text{C}$  and  $^{10}\text{B}$  (fig. 1) and investigation the role of unstable  $^8\text{Be}$  and  $^9\text{B}$  nuclei will be presented.

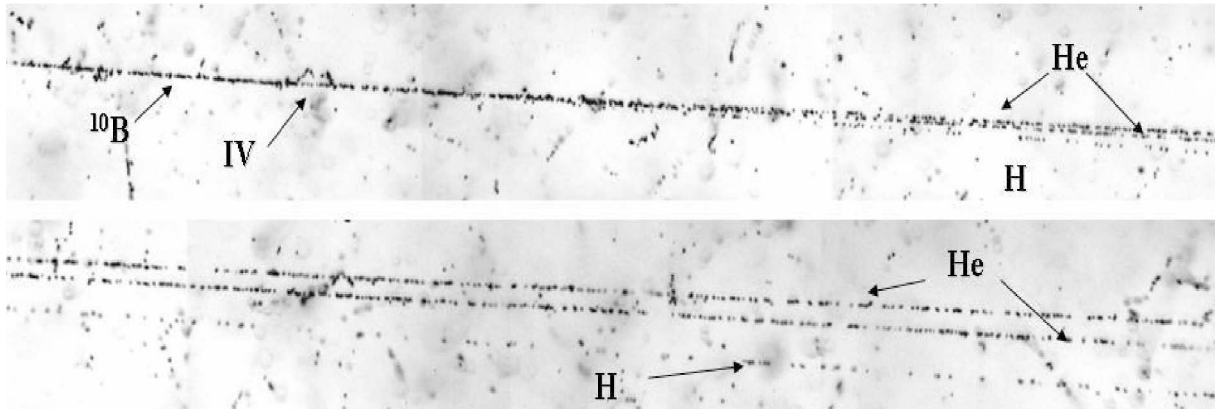

**Fig. 1.** A micrograph one of the events of the nuclear fragmentations in the channel  $^{10}\text{B} \rightarrow 2\text{He} + \text{H}$ . Characteristics of this event:  $\Theta_{2\alpha} = 5.3$  mrad,  $Q_{2\alpha} = 87$  keV,  $Q_{2\alpha p} = 352$  keV.

## DIFFRACTIVE DISSOCIATION OF RELATIVISTIC NUCLEI IN NUCLEAR TRACK EMULSION

P.I. Zarubin<sup>1</sup>,

1. *VI. Veksler and A.M. Baldin Laboratory of High Energy Physics  
Joint Institute for Nuclear Research, Dubna, Russia*

Collective degrees of freedom, in which groups of few nucleons behave as composing clusters, are key aspects of nuclear structure in general. Capabilities of relativistic nuclear physics for the development of the nuclear clustering physics are overviewed. The study of cluster structure in relativistic dissociation has fundamental importance. First of all, the probabilities with which the cluster states are shown in dissociation are related to the fundamental parameters of the ground and excited states of light nuclei. The knowledge of probabilities allows one to determine possible initial configurations of nuclear clusters, which is important for the analysis of the whole variety of nuclear reactions. Clustering is an underlying feature in the physics of nuclear isobars, hypernuclei and quark degrees of freedom. The ideas about nuclear clustering obtained in high-energy physics are important for applications in nuclear astrophysics, cosmic ray physics, nuclear medicine, and perhaps even nuclear geology.

Nuclear track emulsion (NTE) is still retaining its exceptional position as a means for studying the structure of diffractive dissociation of relativistic nuclei owing to the completeness of observation of fragment ensembles and owing to its record spatial resolution [1]. Separation of products of fragmentation and charge-exchange reactions of accelerated stable nuclei make it possible to create beams of radioactive nuclei. A unification of the above possibilities extends the investigation of the clustering phenomena in light radioactive proton-rich nuclei where NTE has special advantages. Conclusions concerning clustering features are based on the probabilities for observing of dissociation channels and on measurements of angular distributions of relativistic fragments. At the JINR Nuclotron exposures of NTE stacks of (NTE) are performed at energy above 1 A GeV to the beams of isotopes Be, B, B, C and N, including radioactive ones. Recent results obtained in this context will be discussed.

In the last decade, the concepts of ultracold dilute nuclear matter based on the condensation of nucleons in the lightest nuclei have been developed. In particular, a concept of an alpha-particle Bose-Einstein condensate is invented. These developments put forward the problem of studying a variety of cluster ensembles and unbound nuclei as fundamental components of novel quantum matter. In a macroscopic scale coherent ensembles of clusters may play an intermediate role in nucleosynthesis, which makes the study of nuclear clustering more important and going beyond the scope of the problems of nuclear structure. They can be searched and, then, studied by means of the NTE technique in diffractive dissociation.

[1] P. I. Zarubin // Lect. Notes in Phys, Springer, 875, 51(2013); arXiv:1309.4881.

# CHARACTERIZATION OF MONOLITHIC ACTIVE PIXEL SENSORS FOR THE NEW ALICE INNER TRACKING SYSTEM PERFORMED AT SPbSU

V.I. Zhrebchevsky<sup>1</sup>, on behalf of the ALICE collaboration

1. *Saint-Petersburg State University, Russia*

*v.zhrebchevsky@spbu.ru*

ALICE (A Large Ion Collider Experiment) has been created at CERN to investigate the physics of strongly interacting matter, in particular, the characteristics of quark-gluon plasma (QGP) formed in relativistic heavy-ion collisions at the Large Hadron Collider (LHC).

The increase of LHC luminosity, which planned for 2020, opens the possibility of expanding the ALICE physics program towards high-precision measurements of rare probes like heavy-flavor hadrons, quarkonia, as well as of dileptons at low transverse momenta. All of these measurements require a significant improvement in vertexing resolution, tracking efficiency, as well as an increase of readout rate. Therefore, the currently running ALICE apparatus, in particular its vertex detector, the Inner Tracking System (ITS), has to be upgraded. The ITS will be replaced by a new, low material, high-resolution detector comprising seven concentric layers of Monolithic Active Pixel Sensors (MAPS) fabricated in the TowerJazz 180nm CMOS Imaging Sensor process [1].

Several MAPS prototypes were produced and studied by ALICE ITS upgrade project to optimize the pixel sensor characteristics. In this work we present results of tests of the latest generation of full-scale prototypes of ALPIDE, called „pALPIDE-3”, performed at SPbSU. pALPIDE-3 measures  $15 \times 30 \text{ mm}^2$  and contains a matrix of  $512 \times 1024$  sensitive pixels, which is divided into eight sectors of  $512 \times 128$  pixels each, differing in charge collection diode geometry and in-pixel circuitry. For the characterization and tests of the ALPIDE prototypes, a test station based on the test board and software, which were jointly developed within the ITS upgrade project, has been set up at SPbSU. To investigate the main characteristics of the pixels, electrical tests and comprehensive studies with a variety of gamma and beta sources were carried out. In addition, the noise characteristics of the sensor and its temperature dependence were intensively studied.

**Acknowledgements.** This work was performed as part of the RF Ministry of Education and Science’s program for Russian teams to participate in the project for modifying the ALICE experiment at the Large Hadron Collider, contract no. 14.610.21.0003, ID number RFMEFI61014X0003. (ID number of St.-Petersburg State University, 11.19.1632.2014).

This work was also supported by the Russian Foundation for Basic Research, project no. 15-32-20546.

## **References**

[1] B. Abelev et al (The ALICE Collaboration), Technical Design Report for the Upgrade of the ALICE Inner Tracking System (2014) J. Phys. G: Nucl. Part. Phys. 41 087002 doi:10.1088/0954-3899/41/8/087002.

# NLO ELECTROWEAK RADIATIVE CORRECTIONS FOR 4-FERMIONIC PROCESS AT BELLE II

A.G. Aleksejevs<sup>1</sup>, S.G. Barkanova<sup>2</sup>, and V.A. Zykunov<sup>3†</sup>

(1) *Memorial University of Newfoundland, Corner Brook, Canada*

(2) *Acadia University, Wolfville, Canada*

(3) *Belarusian State University of Transport, Gomel, Belarus and Joint Institute for Nuclear Research, Dubna, Russia*

† *E-mail: vladimir.zykunov@cern.ch*

We discuss the one-loop (NLO) electroweak radiative corrections (EWC) to the parity-violating and forward-backward asymmetry in  $e^-e^+ \rightarrow \mu^-\mu^+(\gamma)$  process with longitudinally polarized electrons. The calculations are relevant for the ultra-precise low-energy experiments Belle II planned at KEK. While the LHC looks for physics beyond Standard Model directly, at the TeV mass scale, the high-precision measurements like Belle II and MOLLER can provide a unique probe at through the effects of new particles in higher order processes.

We evaluate a complete set of electroweak radiative correction at the NLO level and demonstrate that it is fully under control. The hard photon bremsstrahlung is evaluated specifically for Belle II kinematics, and the possibilities for the soft photon approximation are discussed. We conclude that the scales of the relative corrections to the parity-violating and forward-backward asymmetries are significant, with nontrivial behavior depending on scattering angle and energy cuts. The total numeric analysis for the Belle II conditions is presented.

Let us introduce subscript  $C$  for noting the specific type of contribution in cross section or asymmetries.  $C$  can be 0 (Born contribution), 1 (one-loop EWC contribution), or 0+1 (both these types):  $C = \{0, 1, 0+1\}$ . The parity-violating (or left-right) asymmetry, the forward-backward asymmetry, the left-right asymmetry constructed from integrated cross sections are defined in a traditional way

$$A_{LR}^C = \frac{\sigma_L^C - \sigma_R^C}{\sigma_L^C + \sigma_R^C}, \quad A_{FB}^C = \frac{\Sigma_F^C - \Sigma_B^C}{\Sigma_F^C + \Sigma_B^C}, \quad A_{LR\Sigma}^C = \frac{\Sigma_L^C - \Sigma_R^C}{\Sigma_L^C + \Sigma_R^C}. \quad (4)$$

The subscripts  $L$  and  $R$  on the cross sections  $\sigma \equiv d\sigma/d(\cos\theta)$ , correspond to the polarization degree of electron  $p_B = -1$  and  $p_B = +1$  respectively.

The forward and backward cross sections look like

$$\Sigma_F^C = \int_0^{\cos a} \sigma_{00}^C \cdot d(\cos\theta), \quad \Sigma_B^C = \int_{-\cos a}^0 \sigma_{00}^C \cdot d(\cos\theta).$$

and left and right integrated (over  $a \leq \theta \leq b$  segment) cross sections look like

$$\Sigma_L^C = \int_{\cos b}^{\cos a} \sigma_L^C \cdot d(\cos\theta), \quad \Sigma_R^C = \int_{\cos b}^{\cos a} \sigma_R^C \cdot d(\cos\theta).$$

In Figs below we present all asymmetries with and without radiative effects.

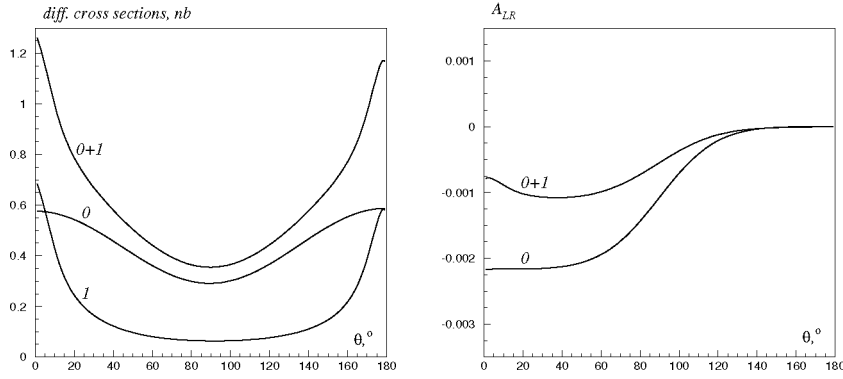

Figure 1: Left: unpolarized NLO corrected (0+1), Born (0), and their difference (1) differential cross sections vs scattering angle  $\theta$ . Right: the polarization Born asymmetry (0) and asymmetry taking into account the NLO EWC (0+1) vs scattering angle  $\theta$ . Note the large contribution of EWC to  $A_{LR}$  at small angles.

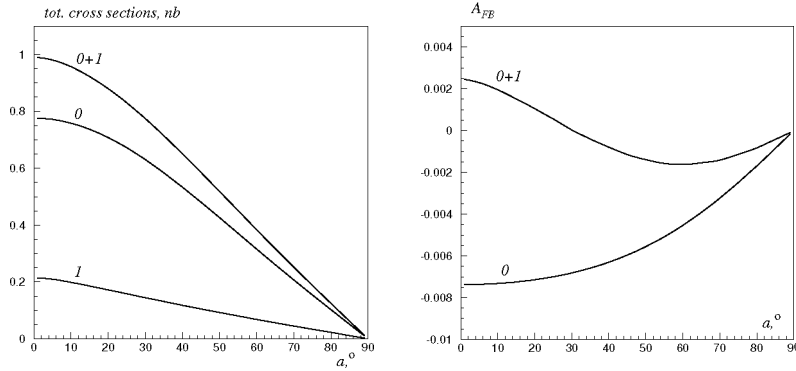

Figure 2: Left: unpolarized NLO corrected (0+1), Born (0), and their difference (1) total cross sections vs angle  $a$ . Right: the forward-backward Born asymmetry (0) and asymmetry taking into account the NLO EWC (0+1) vs angle  $a$ . Note the importance of EWC.

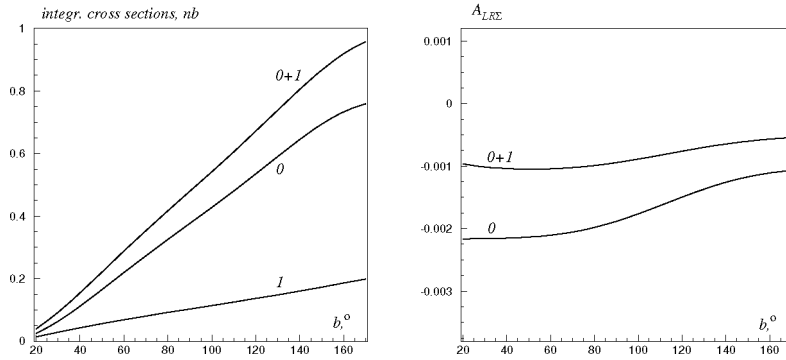

Figure 3: Left: unpolarized NLO corrected (0+1), Born (0), and their difference (1) integrated cross sections vs angle  $b$  at  $a = 10^\circ$ . Right: the left-right integrated Born asymmetry (0) and asymmetry taking into account the NLO EWC (0+1) vs angle  $b$  at  $a = 10^\circ$ .



## **RECENT DEVELOPMENTS IN MPD TRACKING AND DETECTOR PERFORMANCE IN HADRON IDENTIFICATION**

A.I. Zinchenko, A.A. Mudrokh

*JINR*

Simulation of real detector effects with as many details as possible is very important during the study of the detector performance. Some results on realistic simulation of the MPD TPC (Time Projection Chamber) including digitization in central Au+Au collisions were obtained.

A particle identification (PID) is a very important part of physics analysis. Some results of hadron identification including realistic simulation of TPC and simulation of TOF (Time Of Flight) response were also obtained.